

# DMA-BT & WTSD-BT

## DMA & LMA AMPLIFIER BLUETOOTH RECEIVER WALL PLATES

### TECHNICAL DATA SHEET



### PRODUCT SUMMARY

The AtlasIED DMA-BT and WTSD-BT are part of the DMA Digital Mixer Amplifier accessory line and the WTSD active wall plate series. Two versions of the Bluetooth receiver wall plate are available: the DMA-BT, which connects directly to a DMA amplifier, and the WTSD-BT, which connects to any audio system with a balanced line input. Both models use the same Bluetooth receiver wall plate and integrate seamlessly with audio systems.

The DMA-BT connects to the DMA amplifier using an installer friendly, color coded system that utilizes industry standard CAT5/6 cabling and RJ45 connectors. The WTSD-BT functions as a universal Bluetooth receiver and requires a PWBOB analog interface box and external power supply to operate. Wall controllers can be installed up to 330 ft (100 meters) from the amplifier, providing flexible placement options.

Both the DMA BT and WTSD-BT use commercial-grade 5.1 Bluetooth technology featuring ultra-low noise performance, long-range connectivity, no auto-connect function, and a quick disconnect bump feature. The Bluetooth Discovery ID can be customized through the DMA Control App. Installation meets low voltage standards and is straightforward, with the wall plate fitting into a standard single gang electrical box or low voltage ring and requiring only 1.5 inches (38 mm) of clearance depth.

The AtlasIED WTSD proprietary low voltage bus is designed to support a single wall plate or multiple WTSD devices. Up to three WTSD devices can be daisy-chained on the same bus, with audio from each device summed together while maintaining independent control.

The DMA-BT includes an onboard signal limiter to manage the level placed on the summed bus, with adjustable settings from -3 dB to 21 dB. The DMA-BT faceplate provides signal and limiter status indicators.

### KEY FEATURES

- Bluetooth audio receiver
- Customizable Bluetooth discovery name
- No last user auto-connect
- Bump disconnect function
- Color-coded RJ45 interface with DMA series amplifiers
- Utilizes standard Cat5/6 Cable
- Onboard output limiter
- Signal and limit indicator
- Meets low voltage electrical codes
- Fits into 1-gang electrical boxes or low voltage rings
- Can be mounted up to 100 meters from a DMA series amplifier
- Linkable with other WTSD units on the same bus
- WTSD-BT version features interface for connecting to WTSD mixers
- High-gain balanced line output for long distance applications up to 100 meters

### APPLICATIONS

The AtlasIED DMA and LMA Series Amplifiers provide flexible one- or two-zone audio system design, and when paired with DMA-V or DMA-VS wall controllers, the remote level control and source selection provides a streamlined user experience.

- Restaurants
- Presentation rooms
- Retail background/foreground music applications
- Indoor sports complexes
- Schools — gymnasiums, rally areas, classrooms
- Hotels — ballrooms
- Community multi-use facilities
- Industrial facilities
- Coffee shops

# DMA-BT & WTSD-BT

DMA & LMA AMPLIFIER BLUETOOTH RECEIVER WALL PLATES



## TECHNICAL DATA SHEET

### SPECIFICATIONS/PERFORMANCE

System	
Model	DMA-BT
Type	Audio Bluetooth Wall Plate Receiver
Model	WTSD-BT
Type	Audio Bluetooth Receiver Wall Plate & Interface Kit
WTSD Kit Contents	DMA-BT Bluetooth Receiver, PWBOB (Injector), External 24 VDC, 500 mA Power Supply
Inputs - DMA-BT Wall Plate Receiver	
Bluetooth Receiver	
Bluetooth Input	Ultra-low Noise, Long Range Connectivity, No Auto-Connect and Quick Disconnect Bump
Input - Bluetooth Stream	Bluetooth 5.1, Commercial Grade
BLE (Bluetooth Low Energy)	Used for device discovery and Bluetooth ID renaming via the DMA-App
Location	Front Panel
DMA-BT Bus Input	
Input Type - Bus (Proprietary)	(IN) from DMA-ML, WTSD-MIX31, WTSD-MIX41. (Supports any three of these devices daisy-chained – sums audio signal)
Connection	RJ45 (Black)
Audio	Analog Balanced Line (part of bus)
Location	Rear Panel
Network	No. Proprietary WTSD bus.
DMA-BT Bus Output	
Output Type - Bus (Proprietary)	(OUT) to DMA Amplifier WTSD Input, WTSD-PWBOB or WTSD-PWHUB
Connection	RJ45 (Black)
Interface Component	(OUT) to interface with DMA Amplifier WTSD Input, WTSD-PWBOB or WTSD-PWHUB
Network	No.
Controls - Front Panel	
DMA-BT Connect/Disconnect	
Function	Bluetooth Pairing and Override Disconnect
Switch Type	Push, Momentary
Bluetooth Functions	
Bluetooth ID Name	DMA-BT (default). Can be changed via DMA-App.
Momentary Switch - Connecting	Bluetooth pairing and connection
Bluetooth Stream Disconnection	Override Disconnect – terminates any Bluetooth connection.
Last Auto Connect	No
Out-of-Range	Attempts to reconnect within 30 seconds
Bluetooth Range	100 ft. (30 m) minimum – line-of-sight

(CONTINUED ON NEXT PAGE)

# DMA-BT & WTSD-BT

## DMA & LMA AMPLIFIER BLUETOOTH RECEIVER WALL PLATES

### TECHNICAL DATA SHEET



Indicators - DMA Wall Plate Front Panel	
<b>Signal Indicator</b>	
Function	Illuminates when 5 mV of audio signal present at output
Type	Bi-color LED
Color	Green
<b>Limit Indicator</b>	
Function	Illuminates when audio signal triggers limiter threshold
Type	Bi-color LED
Color	Yellow when activated. Rear panel LED activates in parallel.
<b>Bluetooth Indicator</b>	
Function	Illuminates when activation switch is pressed or when a device is paired.
Activation	Incorporated in Pairing/Connect switch
Type	LED
Pairing	Blinking Blue
Bluetooth Connected	Steady-state Blue
<b>DMA-BT Controls - Rear Panel</b>	
Audio Limiter	DMA-BT Audio Signal Output
DIP Switch	3-position: -3 dB, -6 dB, -12 dB settings (Cumulative up to 21 dB)
Switch Location	Rear panel
<b>Limit Indicator - Rear Panel</b>	
Limit	Yellow when activated. Rear panel LED parallels front panel limiter LED.
Function	Illuminates when audio signal triggers limiter threshold. Parallels front panel limit LED.
Type	LED
Color	Yellow when activated. Parallels front panel limit LED.
<b>PWBOB Input - WTSD Kit</b>	
<b>Bus Connection</b>	
Bus Interface	From DMA-BT
Connector	RJ45 (Black)
Location	PWBOB Side
Network	No. Proprietary WTSD bus.
<b>WTSD Power Supply Input</b>	
Connector - Euroblock (Phoenix)	2-position, 3.5 mm pitch
Power Supply Voltage	24 VDC
<b>WTSD PWBOB Output</b>	
Output Bus Type	Proprietary
Connector - Euroblock (Phoenix)	Screw terminal, 6-position, 3.5 mm pitch
Audio Connection	3-position analog balanced line
Other Pins	Other three (3) connections not used with DMA-BT
Location	PWBOB Chassis Side

(CONTINUED ON NEXT PAGE)

# DMA-BT & WTSD-BT

## DMA & LMA AMPLIFIER BLUETOOTH RECEIVER WALL PLATES

### TECHNICAL DATA SHEET

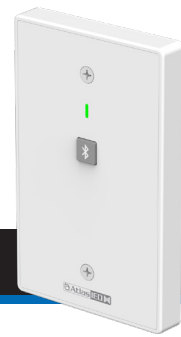

PWBOB Indicators	
Power LED	Green
Output Signal	Green
Other LEDs	Not functional with DMA
Technical Data - DMA-BT	
Bluetooth	Version 5.1, Commercial Grade
Frequency Response	20 Hz - 20 kHz $\pm$ 1 dB
THD	0.1% @ 1 kHz @ 100 ft.
Audio Output	Balanced Line. Maximum Output=4 V
VDC Bus	24 VDC
S/N Ratio	Bluetooth Stream Input: 77 dB @ 100 ft. using Cat5/6 cable <b>Note:</b> Signal unit measurement made with levels set to maximum. Noise Referenced to a 1 V / 0 dBv output. Noise will vary with Cat5/6 cable length.
Signal Indicator on Threshold	5 mV
DMA-BT Interface Connection	
Connector Type	RJ45
Connector Color Code	Black
Connection Interface	To DMA Amplifier WTSD Input and WTSD-PWBOB
Cable Type	Cat5/6 (Suggested)
Maximum Cable Distance	330 Ft. (100 m)
Ambient Operating Conditions - DMA-BT Wall Plate Receiver	
Maximum Temperature	104° F / 40° C
Minimum Operating Temperature	14° F / -10° C
Maximum Humidity	90%
Mounting - DMA-BT Wall Plate Receiver	
Wall Controller Electrical Box	1-Gang Electrical Box. Minimum depth = 2" (55 mm).
Wall Controller Surface Mount	Low Voltage Ring. Minimum clearance = 2" (55 mm).
DMA-BT Power Requirements	
DMA Amplifier - Direct	DMA-BT Connected to DMA WTSD Input
DC Current Draw	110 mA <sup>1</sup>
British Thermal Units	8.5 Btu <sup>1</sup>
DMA-BT Connected to WTSD-PWBOB	
AC Mains	95 V - 260 V, 50/60 Hz
Supply Voltage	24 VDC Bus (24 VDC, 500 mA power supply included with WTSD-BT)
DC Current Draw	110 mA <sup>1</sup>
AC Power Supply Consumption - Amperes	52 mA <sup>1</sup>
AC Power Consumption - Watts	2.5 W <sup>1</sup>
British Thermal Units	8.5 Btu <sup>1</sup>

(CONTINUED ON NEXT PAGE)

# DMA-BT & WTSD-BT

## DMA & LMA AMPLIFIER BLUETOOTH RECEIVER WALL PLATES

### TECHNICAL DATA SHEET



Safety & Certifications - DMA-BT	
Bluetooth	FCC, ICES, CE, Bluetooth Registered

Mechanical - DMA-BT	
Chassis Finish	White
Chassis Material	Plastic and Steel
Product Dimensions (H x W x D1=Mounting Depth and D2=Total)	4.67" x 2.95" x D1 = 1.1", D2 = 1.6" (119 mm x 75 mm x D1 = 28 mm, D2 = 41 mm)
Unit Weight	0.45 lbs. (0.2 kg)

DMA-BT Package Contents	
DMA-BT	Qty. 1
Hardware	Qty. 4, Screw 6/32" x 1" Pan Head, White (2 spares)
Manual QR Code	Qty. 1

WTSD-BT Kit Package Contents	
DMA-BT	Qty. 1
PWBOB	Qty. 1
PWBOB Connectors	Qty 2: 3-position Euroblock (Phoenix), 3.5 mm pitch; Qty 1: 2 position Euroblock (Phoenix), 3.5 mm pitch
Power Supply (24 VDC)	Qty. 1
Hardware	Qty. 4, Screw 6/32" x 1" Pan Head, White (2 spares)
Manual QR Code	Qty. 1

DMA-BT Shipping	
Shipping Dimensions (H x W x D)	6.4" x 4.68" x 3.46" (163 mm x 119 mm x 88 mm)
Shipping Weight	0.66 lbs. (0.3 kg)

WTSD-BT Shipping	
Shipping Dimensions (H x W x D)	3.46" x 4.68" x 6.4" (88 mm x 119 mm x 163 mm)
Shipping Weight	1.32 lbs. (0.6 kg)

#### Notes:

- 1 - Average current draw, watts, and Btu are based on one DMA-BT or WTSD-BT. For each additional WTSD or DMA-BT/ML added in series, calculate the total draw. Examples:  
Two WTSDs=104 mA of DC current draw.  
Three WTSDs=156 mA of DC current draw.
- 2 - Electrical box requirements. For additional information, refer to manual for recommended box types.

# DMA-BT & WTSD-BT

DMA & LMA AMPLIFIER BLUETOOTH RECEIVER WALL PLATES

TECHNICAL DATA SHEET



## PRODUCT IMAGES & DIMENSIONS

### DMA-BT

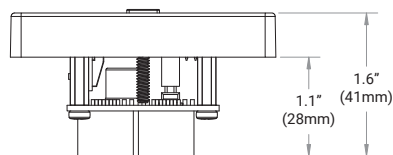
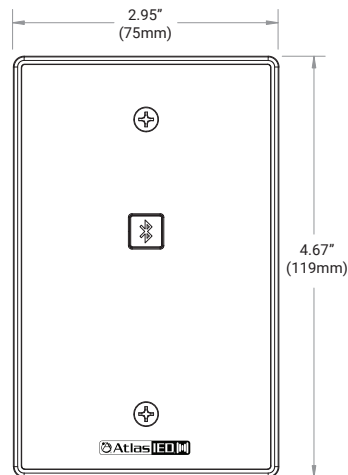
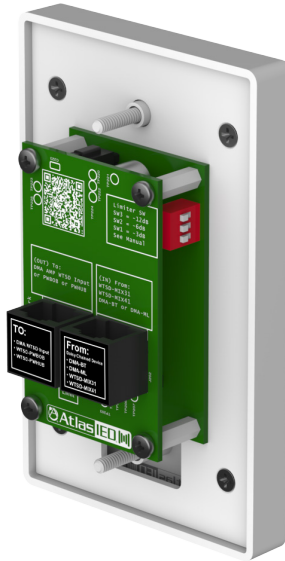
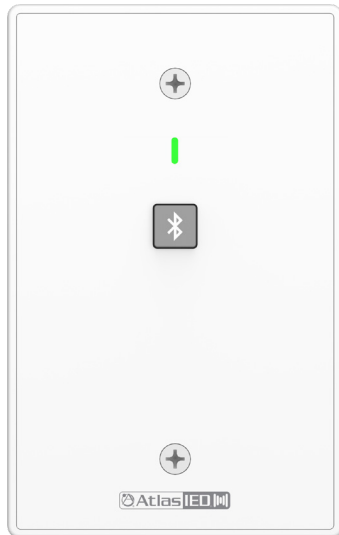

# DMA-BT & WTSD-BT

DMA & LMA AMPLIFIER BLUETOOTH RECEIVER WALL PLATES

TECHNICAL DATA SHEET



## PRODUCT IMAGES & CONNECTIONS

### WTSD-BT

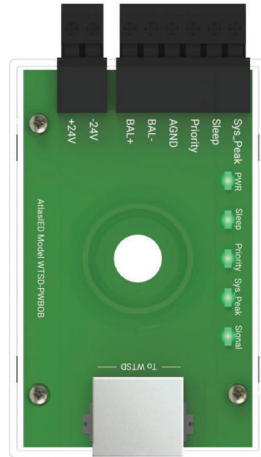

### DMA Amplifier & DMA-BT



# DMA-BT & WTSD-BT

DMA & LMA AMPLIFIER BLUETOOTH RECEIVER WALL PLATES

TECHNICAL DATA SHEET



## PRODUCT CONNECTIONS

### WTSD-BT (Kit)

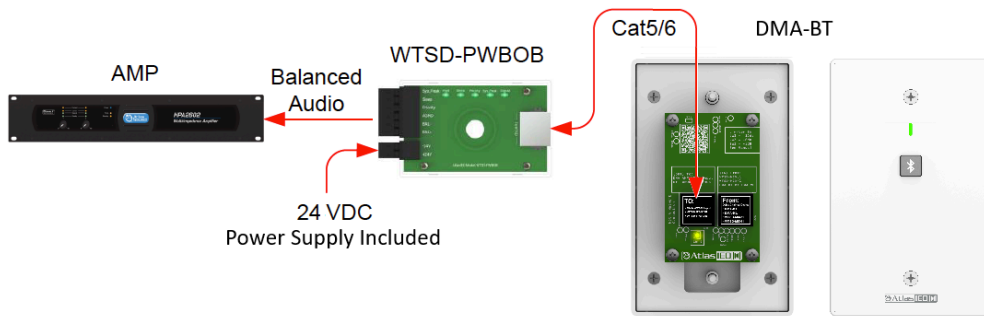

### DMA Amplifier & 3 Wall Plate Accessories in Series

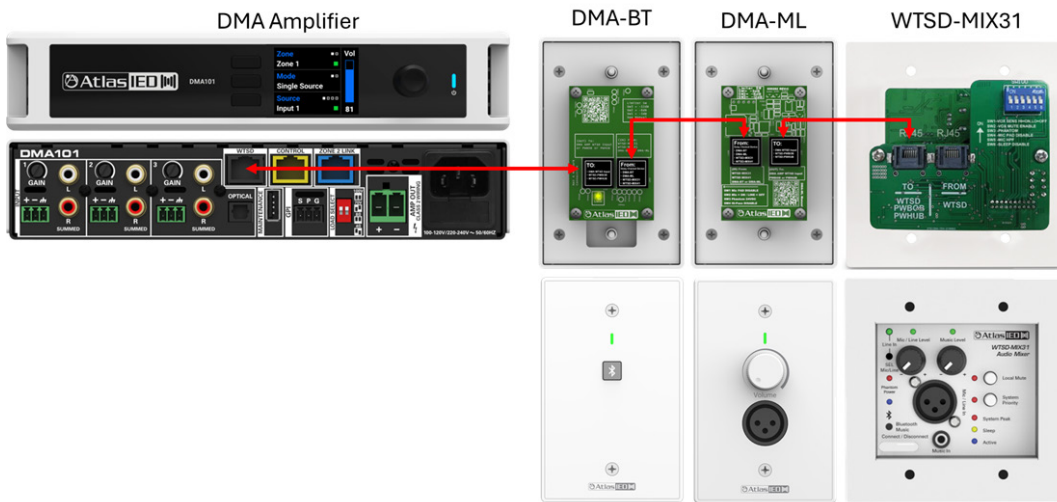

### WTSD-BT Audio Converter to Dante® Digital Audio

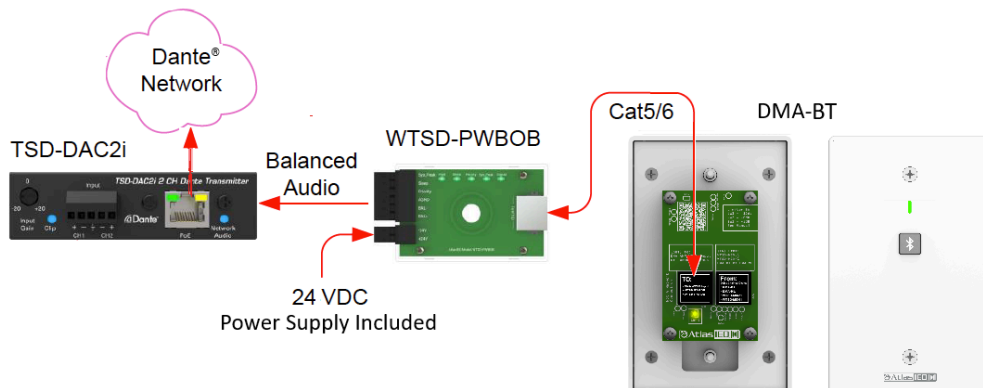

# DMA-BT & WTSD-BT

## DMA & LMA AMPLIFIER BLUETOOTH RECEIVER WALL PLATES

### TECHNICAL DATA SHEET



### ARCHITECT AND ENGINEER SPECS

The Bluetooth receiver wall plate shall be the AtlasIED DMA-BT or WTSD-BT, designed as part of the AtlasIED DMA Digital Mixer Amplifier accessory line and WTSD active wall plate series. The device shall provide wireless audio input via commercial grade Bluetooth technology featuring low noise performance, extended range connectivity, no auto-connect functionality, and a quick disconnect bump feature. The Bluetooth Discovery ID shall be field configurable through the DMA Control App.

The DMA BT model shall interface directly with AtlasIED DMA Series amplifiers using a color coded connection scheme with industry standard CAT5/6 cabling and RJ45 connectors. The WTSD BT model shall function as a universal Bluetooth receiver capable of integration with any audio system utilizing a balanced line level input and shall require a PWBOB analog interface box and external power supply.

Both models shall utilize the same single gang Bluetooth receiver wall plate, suitable for installation in a standard single gang electrical box or low voltage ring with a minimum depth requirement of 1.5 inches (38 mm). Wall plates shall support cable runs up to 330 ft (100 m) from the associated amplifier or interface device.

The WTSD BT shall operate on the AtlasIED proprietary low voltage WTSD BUS, supporting up to three daisy chained WTSD devices with summed audio and independent device control. The DMA BT shall include an onboard signal limiter with adjustable settings from -3 dB to +21 dB to regulate signal contribution to the summed bus. The DMA BT faceplate shall include signal and limiter status indicators.

Dimensions for both wall plate models shall be the same with the (Height) 4.67" x (Width) 2.95" x (Mounting Depth) 1.1" (119 mm x 75 mm x 28 mm). Weight shall be 0.45 lbs (0.2 kg).

The AtlasIED accessory wall plate shall be the DMA-BT and the WTSD-BT.

©2026 Atlas Sound LP. The Atlas "Circle A" Soundolier, and Atlas Sound are trademarks of Atlas Sound LP. IED is a Registered Trademark of Innovative Electronic Designs LLC. All rights reserved. All other Trademarks are property of their respective owners. No endorsement is implied. Due to continual product development, specifications are subject to change without notice. AT5008579 RevB 6/26