

FOHNN® BEAM STEERING TECHNOLOGY.



REFERENCES
APPLICATIONS
OPPORTUNITIES

DESIGN

INNOVATION

SOUND

FUTURE

FOHNN. THE EXPERTS IN BEAM STEERING.

Perfect sound in challenging acoustics.
Perfect architectural integration.
A visionary concept.

From **Fohhn**. The Experts in Beam Steering.

References.
Applications.
Opportunities.

Fohhn[®]
Focus Modular
und Linea Focus

INNOVATIVE SOUND SYSTEMS WITH
FOHNN[®] BEAM STEERING TECHNOLOGY.

FOCUS MODULAR REFERENCES

Page 4

LINEA FOCUS REFERENCES

Page 38

TECHNOLOGY

Page 70

Fohhn® Beam Steering: Sound reinforcement technology of the future.

Fohhn's award-winning Focus Series has redefined the concept of sound reinforcement in complex acoustic environments. Equipped with state-of-the-art Beam Steering Technology, the systems have been specially designed to offer intelligent, directional coverage of rooms with challenging acoustic conditions, in order to give the best possible results.

The beam characteristics of loudspeaker systems featuring Fohhn® Beam Steering Technology can be remotely controlled and individually adjusted to suit the acoustics of a particular venue. Control is carried out in real time, using a single piece of software. By comparison, conventional loudspeaker systems do not have adjustable beam characteristics so their sound cannot be as precisely directed within the room, making it prone to reflections from the ceiling, floor or wall. The result of this can be unpleasant for the listener, with washy, reverberant sound. For these situations, Fohhn® Beam Steering Technology provides a perfect solution: the beam can be precisely directed towards the listeners, minimizing the effect of unwanted room reflections and giving excellent levels of speech intelligibility throughout. Even in the most challenging acoustic conditions, the result is both clear and pleasant, not only for speech but also for music. A Fohhn® Beam Steering system consists of a number of individual loudspeakers arranged in a column within a slim elegant housing (a loudspeaker array). Each

speaker has its own amplifier and DSP channel, allowing it can be individually adjusted. Using a complex algorithm, both the vertical width and the inclination angle of the beam to be remotely controlled via software.

The sound experts at Fohhn® have become world leaders in the development of this new technology. Constant refinements have been made to Fohhn's beam steering technology since 2008, culminating in today's unique level of performance capability. Fohhn® systems can be intuitively controlled in real time, via software, with ultra-fine adjustment of beam characteristics in increments of 0.1°. Such precision enables the beam to be trained so that unwanted effects, such as side lobes, are suppressed – to mention just a few of the systems' many innovative features.

Offering over 10 different products in total, Fohhn's award-winning "Linea Focus" and "Focus Modular" beam steering systems cater for the entire spectrum of acoustic settings and venue sizes, from conference rooms, cathedrals and concert halls to airports, exhibition halls and stadia. Proof of the loudspeakers' impressive credentials can already be seen in a wide range of conducted events and successfully installed beam steering systems.

**PERFECT EVEN IN THE MOST CHALLENGING
ACOUSTIC CONDITIONS**



**PERFECT FOR ALMOST
INVISIBLE INTEGRATION**



**PERFECT FOR DEMANDING LIVE
SOUND APPLICATIONS**



FOCUS MODULAR SYSTEM

FMI-100 + 2×FMI-400 + FMI-110

FOCUS MODULAR SYSTEM

FMI-100 + 2×FMI-400 + FMI-110

FOCUS MODULAR SYSTEM

FMI-400 + FMI-110

Elegance meets functionality.

FESTIVAL THEATRE VCC RECKLINGHAUSEN, GERMANY

Barely visible at first glance, yet fully functional. Exactly what the architects and staff at the Ruhr Festival Theatre had in mind. The perfectly designed Focus Modular series brings superior sound quality to every single row, as well as appearing slimmer and less obtrusive than conventional loudspeaker systems. More importantly, Fohhn® has also managed to solve a crucial problem: With conventional line arrays discounted on visual grounds, and smaller beam steering systems alone not considered powerful enough, Focus Modular's unique combination of elegance and functionality made it the only real choice here.



Sound reinforcement for front rows: ultra-compact Fohhn® LX-10 systems. Stage monitors: Fohhn® XM-4. Subwoofer systems integrated in stage: AS-40 (cardioid) and PS-9.

STATEMENT OF MARTIN ROSS, TECHNICAL MANAGER VCC RECKLINGHAUSEN

“The theatre hosts a lot of guest performances, so we needed a system that would enable us to cover all kinds of events without having to continually set it up and dismantle it. At the same time, it needed to be suitable for various types of music reproduction, as well as being visually unobtrusive. Conventional line arrays would

potentially interfere with the stage set, so they could not be left hanging for every event. With Focus Modular however, we have managed to kill two birds with one stone, achieving an extremely even sound coverage from the stalls right up to the balcony, while effectively integrating the systems into the theatre architecture.”



← BALCONY

Invariably a problem area, the distance from the stage portal to the back row of the balcony is around 40 metres. This distance requires a sound system that can provide highly directional high-mid range coverage in order to guarantee excellent speech intelligibility and clear sound reproduction.

↓ STAGE PORTAL

The two Focus Modular combinations mounted to the left and right of the stage portal are just 22cm wide, but over 4.27 metres high. These act as the main sound system and are capable of covering every single row of theatre seating. The total line length of the loudspeakers, combined with their integral beam steering technology, means that the system can provide precise, controlled coverage over a very wide frequency range. The result is an extremely even sound with optimum levels of speech intelligibility on every single row.

CENTRAL CLUSTER →

Focus Modular FMI-400 low-mid and FMI-110 high frequency modules have been installed above the centre of the stage. For visual reasons, the modules have been mounted adjacent to each other. Each loudspeaker can produce two separate beams (Fohhn® Two Beam Technology), enabling simultaneous coverage of both upper and lower seating levels. The purpose of this central cluster is to create an acoustic location in the middle of the stage, should the production require it.

FMI-400
see right side

FMI-110
see right side



FMI-100

Active, electronically steerable high frequency module equipped with 8 x 1" high performance, high frequency drivers, waveguide and horn. Provides the balcony with crystal clear sound.

FMI-400

Active, electronically steerable low-mid module containing 32 x 4" high performance speakers. Both modules are linked to produce a unified effect, working together in "Two Beam Mode" to produce separate beams for precise coverage of the stalls and balcony.

FMI-400

see above

FMI-110

Active, electronically steerable high frequency module equipped with 16 x 1" high performance, high frequency drivers, waveguide and horn. Provides precisely targeted mid to high coverage of the stalls.

FOCUS MODULAR SYSTEM

FM-110 + 2×FM-400 + FM-100

Exhibition space ...

FOCUS MODULAR SYSTEM

FM-110 + 2×FM-400 + FM-100

Important events and artists attract large audiences. But finding the right location for a large-scale event can be difficult, with choice often limited to venues like sports arenas or exhibition halls. High-quality productions involving speech and music can be challenging to stage in these settings, with the sound quality often compromised by lengthy reverberation times and echoes.

Fohhn® Beam Steering Technology offers an audible improvement in these situations, bringing the concert hall listening experience a step closer. Highly accurate control of loudspeaker beams means less excitement of any problematic room acoustics, to the extent that they become barely noticeable. Even an orchestra sounds exactly as it should: full, powerful and enjoyable.

Exhibition space ...

CORPORATE EVENT AT THE COLOGNE MESSE, GERMANY



FOCUS MODULAR SYSTEM

FM-110 + 2x FM-400 + FM-100

60 top-quality microphones and Focus Modular provide perfect reinforcement for the orchestra.

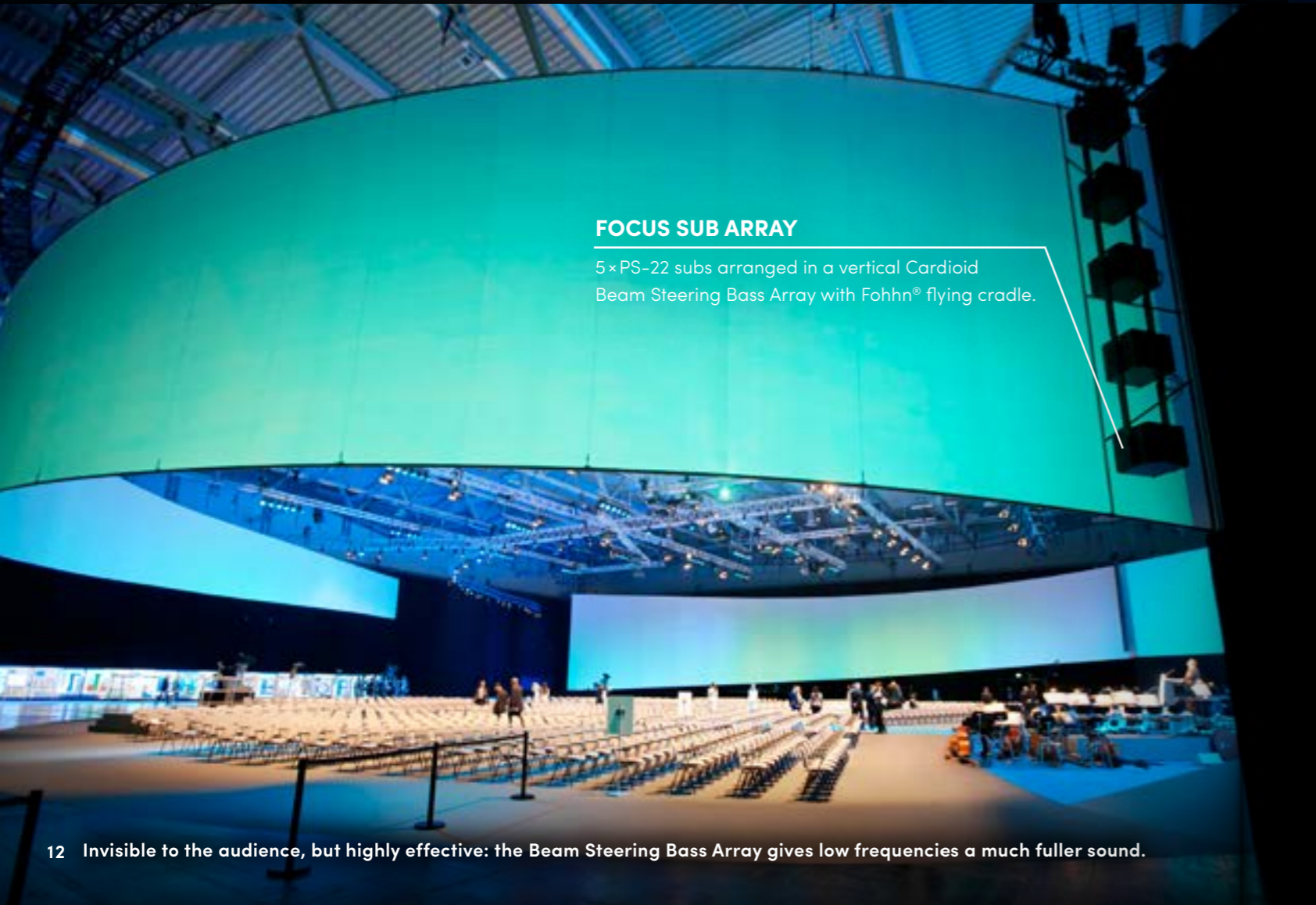

FOCUS SUB ARRAY

5x PS-22 subs arranged in a vertical Cardioid Beam Steering Bass Array with Fohhn® flying cradle.

12 Invisible to the audience, but highly effective: the Beam Steering Bass Array gives low frequencies a much fuller sound.

... or concert hall? Both!

STATEMENT OF STEFAN STEFFENS, SOUND ENGINEER

"I had the pleasure of mixing FOH orchestral sound for this amazing corporate event using the brand new Focus Modular systems. After some initial skepticism about using a beam steering system for an event involving over 60 open orchestral microphones, I soon revised my opinion. The system performed superbly from the outset and I had absolutely no problem with the side lobes frequently experienced when using other systems. I had also found that other systems were prone to unpredictable feedback when used in conjunction with moving microphones (headsets), or "very hot" mics. Compared with previous experiences, the system response was very linear, with feedback frequencies narrowed down to just a couple of inevitably occurring instances due to microphone placement. All in all, I have to say that I was quite astounded by what Fohhn have produced.

I'd particularly like to thank Ralf Freudenberg for all his support. He built us a bass array that functioned magnificently. Used in combination with the PS-9, it left nothing else to be desired in the low frequency range. My thanks also to Fohhn for designing a cool system that will hopefully see frequent use in challenging sound reinforcement situations, as well as for the support given at the venue."

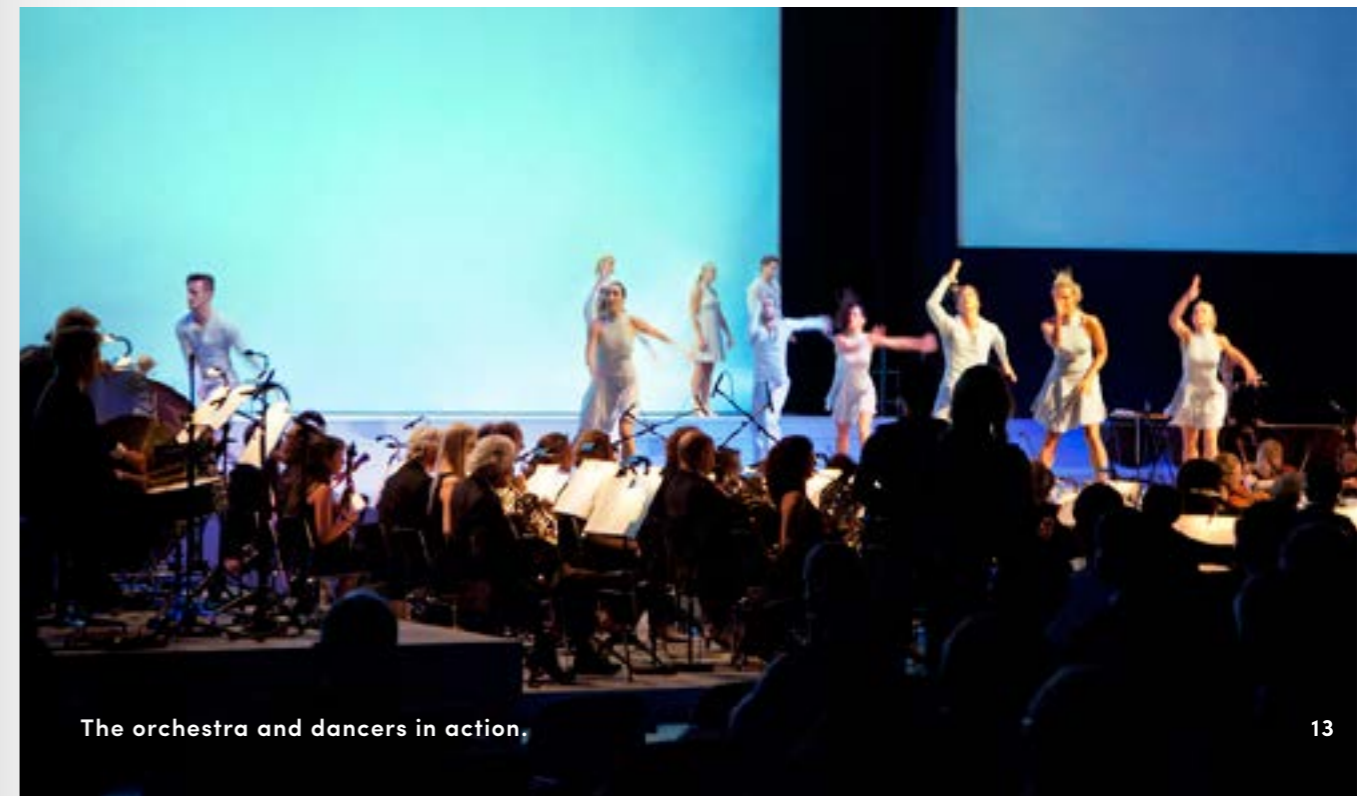

The orchestra and dancers in action.

Perfect orchestral sound in the magic triangle.

OPERA SCHENKENBERG, ZURICH, SWITZERLAND

FOCUS MODULAR SYSTEM

FM-110 + 2×FM-400, with rain covers

FOCUS MODULAR SYSTEM

FM-110 + 2×FM-400, with rain covers

From the early planning stages of this project, the “magic triangle” kept us extremely busy. How do you cover a triangular audience grandstand as successfully as a more conventional circular or rectangular seating arrangement? Answer: directly from the front of the stage, with perfectly integrated, virtually invisible Focus Modular systems. Verdi’s opera “Il Trovatore” provided further magic, offering a stunning experience for both eyes and ears.



**STATEMENT OF HOLGER URBACH,
SOUND DESIGNER FOR OPERA SCHENKENBERG 2013**

“As a sound engineer and producer of classical music recordings, I had the pleasure of developing the technically elaborate sound design for Opera Schenkenberg 2013, an artistically acclaimed open air project.

Quite by chance, I had seen Fohhn Focus Modular systems at the Tonmeister-tagung 2012 and was quickly convinced that these would be my “tools” for sound coverage at “Il Trovatore” in the summer of 2013. Their magnificent sound, similar to that of an oversized studio monitor, combined with their subtle integration into the staging structure, left me, my colleagues and in particular the public, completely convinced. An additional plus was the real-time control of the loudspeaker beams while calibrating the system.

Congratulations on an excellent product!”

Born in Frankfurt/Main, Holger Urbach studied at the University of Heidelberg and at the Robert-Schumann-Hochschule in Düsseldorf. Urbach has worked with the Vienna Symphony Orchestra, the London Philharmonic and London Symphony Orchestras, the Orchestre National de Lyon, the Tonhalle-Orchester Zürich, I Soloisti Italiani, La Petite Bande, the Orquestra Nacional de Porto, Musikkollegium Winterthur and many others. His CD recordings, covering a variety of genres, have been awarded various accolades including the German Record Critics’ Prize, ECHO Klassik, Diapason d’Or, BBC Music Award and the Japanese Disc Prize. Since 2010 he has worked as sound director for a number of large-scale open-air events. He lectures at the Association of German Sound Engineers conferences and at AES, as well as teaching at the University of Applied Sciences in Düsseldorf.



Crystal Clear Sound.

LEIPZIG GLASHALLE, GERMANY



The Glashalle at Leipzig Messe is the largest of its type in Europe. Its bright interior is flooded with natural light and topped by a 25,000 square metre glass dome supported by an imposing steel construction. Created by London-based architect Ian Ritchie, who also worked on the construction of the glass pyramid at the Louvre in Paris, the glass dome has not only proved to be a technical masterpiece, but also an acoustic challenge. Whatever the occasion – ball, reception, gala, or corporate event – a highly directional sound system is required, whose beams will not stray onto the plethora of reflective surfaces including the stone floor and glass ceiling. The sound system also needs to be powerful enough to provide coverage for up to 4500 people. Fohhn® Focus Modular with Beam Steering Technology prove the perfect solution.

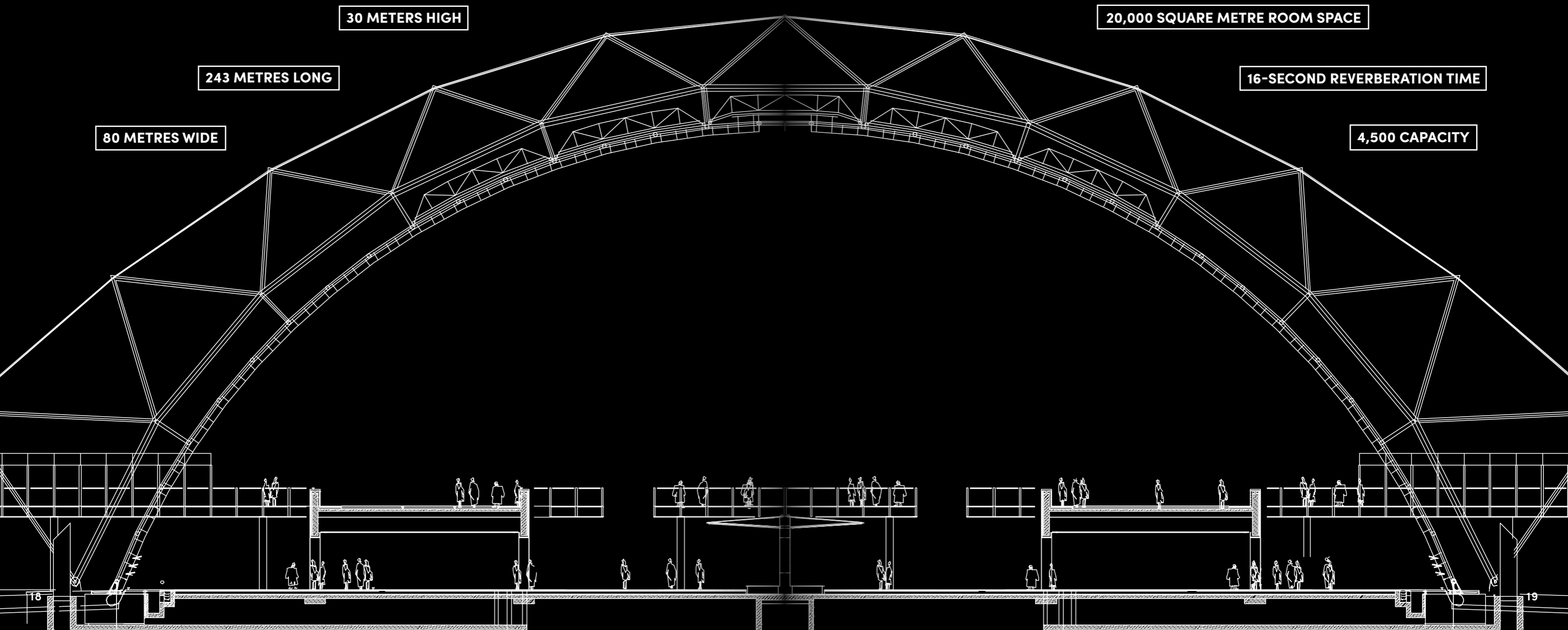

FOCUS MODULAR SYSTEM

FM-400 + FM-110

FOCUS MODULAR SYSTEM

FM-400 + FM-110

FOCUS MODULAR FM-110

FOCUS MODULAR FM-110

FOCUS MODULAR SYSTEM

FM-110 + 2xFM-400

FOCUS MODULAR SYSTEM

FM-110 + 2xFM-400

Crystal Clear Sound in the Glashalle.

ADAM & EVA AWARDS 2013, GLASHALLE, LEIPZIG, GERMANY

Statement of Omar Samhoun, Project Leader / Sound Engineer, Neumann & Müller

"Sound coverage in the Glashalle, Leipzig, presents a real challenge. Before we had our Focus Modular systems, we had to suspend a large number of compact loudspeakers from the ceiling. Installing and calibrating these systems took forever. For this year's Adam & Eva Awards however,

we used two Focus Modular FM-400 low-mid and FM-110 high frequency combinations as our main L/R system. In the centre we used two FM-110 systems; and for delay lines, an FM-400/FM-110 combination on each side. The installation itself only took two hours. Calibrating all the systems took a further two hours, and that was it! The end result was superb. Speech intelligibility was excellent, while the music and live acts sounded really powerful."



FOCUS MODULAR SYSTEM

FM-110 + FM-400, with rain covers

Main sound system: Focus Modular.
 Side fills: LX-601; Performance area coverage / monitoring: LX-150;
 Positioning system/TiMax: XT-10; Effects loudspeakers: XT-33; Subwoofers: PS-9

FOCUS MODULAR SYSTEM

FM-110 + FM-400, with rain covers

Beschallung & Support: Sennheiser Schweiz AG



FOCUS MODULAR SYSTEM

FM-110 + 2x FM-400, covered with sound-permeable material

Great Sound for the “Great World Theatre”.

WORLD THEATRE, EINSIEDELN, SWITZERLAND

The traditional “Great World Theatre” has been performed as an open-air production in the courtyard of Einsiedeln Abbey, Switzerland, since 1924. The size of the production has however grown spectacularly, with over 300 actors taking part in the 2013 performances under the direction of Beat Fäh, accompanied by a team of professional artistic collaborators. The main grandstand offered seating for over 2,700 spectators, while the performance area covered a massive 60 x 200 metres. 40 performances took place during the season.

Focus Modular systems provided the main sound coverage, unobtrusively mounted on scaffolding at a distance of 40 metres from the grandstands.



↑ SEAMLESS INTEGRATION

The furthest placed Focus Modular systems were at the door of the abbey itself. Barely visible at first glance, they were cleverly disguised to blend with the surroundings. The distance from the loudspeakers to the furthest spectator was around 80 metres, however, any acoustic events happening near the abbey walls were so perfectly transmitted, along with their correct positioning, that they could be clearly heard and understood by every member of the audience.

FOCUS MODULAR SYSTEM

1×FM-100, 2×FM-400, 1×FM-110

FOCUS MODULAR SYSTEM

1×FM-100, 2×FM-400, 1×FM-110

The Wise Guys great songs, great sound.

BEETHOVENHALLE, BONN, GERMANY

Currently hailed as Germany's number 1 vocal band, The Wise Guys are also one of the most successful live German language acts. Their songs are as unique as their sound. Using just five voices, the band delivers a sound that is more typical of a full-blown pop group. The Wise Guys' last four studio CDs have taken them into the top 3 of the charts, so it's no surprise that, together with Focus Modular, they thrilled the audience during their Christmas concert at the Beethovenhalle in Bonn. The band has already completed several highly successful church tours using Linea Focus systems.



Stage monitoring and front fills: Fohhn® LX-11, subwoofer systems: PS-9 (cardioid)

STATEMENT OF REINHARD KLOSE, SOUND ENGINEER "THE WISE GUYS"

"We'd already had extremely good results with Linea Focus beam steering systems on The Wise Guys' 2012 and 2013 church tours. On 22nd December 2013, we had a very ambitious Christmas concert at the Beethovenhalle in Bonn together with the Vox Bona choir. For this event I was keen to try Fohhn's Focus Modular systems, as the venue has a reputation for being acoustically challenging. What's more, in addition to our usual microphone set-up, we would have to take the 48-piece Vox Bona Choir into consideration. The results achieved from

two front facing Focus Modular arrays were really good. Once again I was amazed at the minimal amount of acoustic excitement from the room, especially around the stage area, as well as the even sound coverage from the front to the back rows – and all that from just two systems ..."

Reinhard Klose is a lecturer at the "Institut für Musik & Medien / Robert Schumann" in Düsseldorf and a guest lecturer at the ARD/ZDF Medienakademie in Nürnberg, Germany.



Events are regularly hosted in the building's attractively designed foyer. Reverberant acoustics have resulted in the choice of Fohhn® beam steering systems: two mobile Linea Focus LF-350 systems in white, on Freestand Designer Stands, in combination with a XS-30 active subwoofer, when required and positioned to suit the particular event.



FOCUS SUB ARRAY

horizontal arrangement of 4×XS-20 active and 4×XSP-2 integrated into the wall

Catering for events of all kinds, eight Fohhn® subwoofer systems have been integrated into the wall, providing a full, warm bass sound for both music reproduction and live acts. Arranged to form a horizontal array, the systems can be electronically steered using Fohhn® Audio Soft software, ensuring even and controlled bass coverage at all times.

Planning and installation: Informationsteknik Scandinavia A/S, Copenhagen

Scandinavian design – elegance without compromise.

DI HEADQUARTERS, COPENHAGEN, DENMARK

It's been a while since an installation project involved quite so many architectural considerations for the sound system. However, with sharp, simple lines a recognised feature of all Scandinavian design, it was decided by the end of the planning stage that the loudspeakers should be integrated into the wall, like the projection screen. Front facing, clear and acoustically perfect.



FOCUS MODULAR FMI-110 + FMI-400

White, RAL 9016, integrated into the wall

PERFECT LINES.

Mechanically and electronically linked with one another and safely flown in the shortest possible time: two **Focus Modular** FM/I-400 low-mid modules and one FM/I-110 high frequency module. This system can generate a sound pressure level of over 100 dBA at a distance of 100 metres.



POWERFUL POTENTIAL.

Developed by Fohhn® engineers, Focus Modular high frequency modules enable enormous sound pressure levels to be produced in the 1.000 Hz - 20.000 Hz frequency range. This guarantees highest levels of speech intelligibility and a transparent, pleasing sound even at long distances.



This close-up of a Focus Modular high frequency unit reveals Fohhn's high performance Waveguide-Horn system with state-of-the-art 1" neodymium drivers. The modules are available with either 8 or 16 high frequency drivers arranged in a column, enabling sound pressure levels of up to 148dB/1 metre to be achieved. This capability can not be achieved by regular line source systems with high frequency dome tweeters.

FOCUS MODULAR.

Detailed view of front panel with acoustically perfected steel honeycomb structure, powder coated in housing colour, ball impact resistant. End panel with powder coated sunken aluminium hand grip. Housing made from Birch plywood, Class AA, waterproof glued, notched and screwed. Polyurethane coating. Available in all RAL colours.



JUST 22 CM WIDE

24 cm deep



FM/I-400

FM/I-110

FM/I-100

The three Focus Modular high frequency and low-mid modules can all be combined and cascaded to meet virtually any sound reinforcement requirement. The system can also be dismantled at any time. Modules are available in both fixed installation (conforming to EN-60849 standard) and mobile versions.

LINEA FOCUS.

ACTUAL SIZE

JUST 13 CM WIDE

12 cm deep

The loudspeakers' elegant aluminium housing with designer front grille integrates perfectly into any architectural setting. Linea Focus systems are available in all RAL Colours. Front grille powder coated in housing colour.



ENGINEERED FOR ARCHITECTURE AND LIVE SOUND.

Linea Focus systems offer exciting new possibilities for fixed installation and live sound. Catering for different requirements, two models are available for mobile applications and four models for system integration. The model types are virtually identical from an electronic and acoustic perspective, differing only with regard to some of the design features and connections. Fixed installation versions conform to the EN-60849 standard and are equipped with an internal connection panel. Connections for mobile Linea Focus versions are directly accessible from the underside of the systems.

CONSISTENT INTELLIGENCE. THE LINEA FOCUS FAMILY.

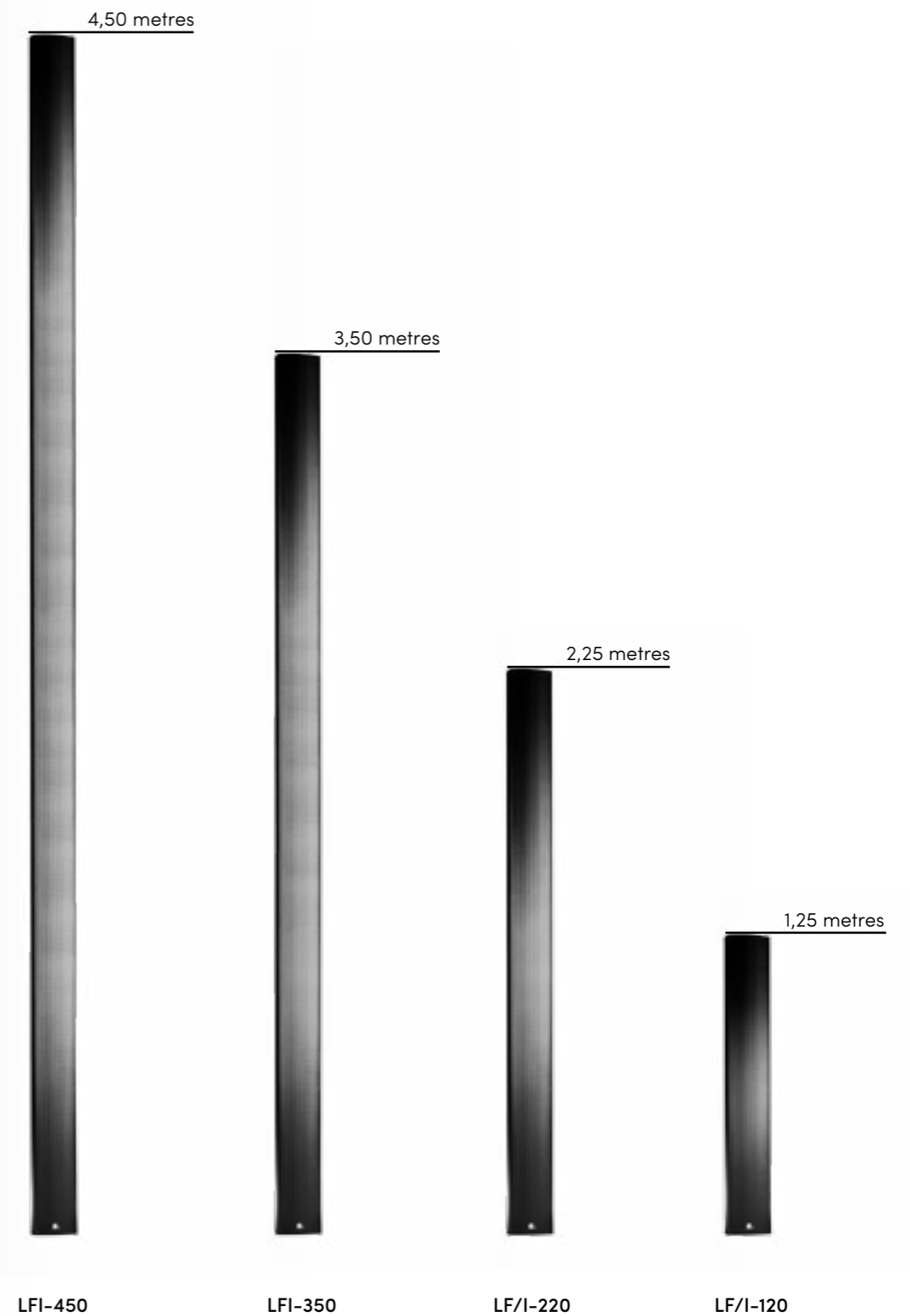

The Linea Focus family. The various models belonging to this innovative, finely-tuned loudspeaker family differ mainly in their respective lengths. This is due to the number of individually controlled loudspeakers, amplifiers and DSP channels in each. The longer each line array is, the longer its reach and the greater its ability to provide more targeted low frequency coverage.

LINEA FOCUS LFI-120

hidden behind sound permeable material

See the impressive exhibits,
but not the impressive
loudspeakers.

GERMAN HYGIENE MUSEUM, DRESDEN, GERMANY

Exhibitions held at the German Hygiene Museum are far more versatile and interesting than the name might at first suggest. The busy venue also plays host to a range of conferences, lectures and concerts.

2010 saw the renovation of the museum's main function rooms, which included very specific requirements for the new sound systems. No loudspeakers could be visible in the historically protected, classical modernist style building, so systems have had to be installed in the wall itself, hidden behind special sound permeable material. As mechanical adjustment is impossible, Linea Focus systems have proved perfect for guaranteeing direct, high-quality audience coverage.

LINEA FOCUS LFI-120

hidden behind sound permeable material

LINEA FOCUS LFI-220

hidden behind sound permeable material

LINEA FOCUS LFI-220

hidden behind sound permeable material



Ready for take off.

CHARLES DE GAULLE AIRPORT,
PARIS, FRANCE

As passengers at CDG airport prepare for take off to their dream destinations, it's crucial that all announcements can be clearly heard. Which gate is the flight departing from? Are there any sudden changes? Fortunately Fohhn's state-of-the-art Linea Focus LFI-220 systems make sure that a relaxing holiday gets off to a flying start.

LINEA FOCUS LFI-220





LINEA FOCUS LFI-220
special colour RAL-1015

LINEA FOCUS LFI-220
special colour RAL-1015

System integration: Centron Slovakia

History, culture ...

REDUTA CONCERT HALL, BRATISLAVA, SLOVAKIA

From the outset of this unique project, one thing was made very clear: Neither conventional loudspeakers nor curved line arrays would be suitable for use due to their appearance. A special loudspeaker system was required, in a light ivory colour (RAL-1015) that would not only match the hall's interior, but also provide coverage of the entire room from the stage portal. Additional loudspeakers were not wanted elsewhere in the hall – the system had to be capable of covering both the stalls and also the balcony area as required.

... and sound sophistication.

Fortunately, Linea Focus makes all that possible: The loudspeaker beam is basically directed onto the audience in the stalls, however, a second independent beam for the balcony area can also be turned on or off as required at the touch of a button (or computer key). The loudspeaker system also needed to have the ability to be used for voice alarms in case of fire or other emergency. Not a problem either, since Linea Focus systems are factory fitted with a second signal input and priority switching for the transmission of emergency evacuation announcements ... although we hope that this particular feature won't ever be needed here ...

Learning is only successful if everything can be clearly heard.

UNIVERSITY OF HEIDELBERG, GERMANY

Heidelberg University is one of the world's oldest seats of learning. With 12 faculties and over 28,000 students, the distinguished institution celebrated its 625th anniversary in 2011. This coincided with a programme of renovation that included the 400-seat "Hörsaal 13" lecture theatre along with the 650-seat Neue Aula, which was completed in 2012.

The refurbishment of the rooms had to comply with the university's protected building status, as well as meeting its state-of-the-art technical requirements. New sound systems needed to blend unobtrusively into the historic architecture, while at the same time providing clear coverage and excellent levels of speech intelligibility. Learning is only successful if everything can be clearly heard.



LINEA FOCUS LFI-220

White, RAL-9010

LINEA FOCUS LFI-220

White, RAL-9010



LINEA FOCUS LFI-220

LINEA FOCUS LFI-220

Good for the eyes and ears! Students have clear sound and vision.

UNIVERSITY OF AMSTERDAM, NETHERLANDS

Following the trend set by many modern football stadia, seating in lecture theatres is often steeply tiered in order to give all students the best possible view. But, what's good for the eyes isn't always good for the ears. In this situation, the sound system needs to provide even coverage throughout the room – for example from the front row that is 2 metres away, to the back row that is 40 metres away and 12 metres higher than the front row. Seems impossible? ... Not with Fohhn® Beam Steering Technology.

Each system can generate two separate beams: The front rows can be covered by a shorter beam with reduced level, while back row coverage is taken care of with a longer full-powered beam. In comparison with conventional loudspeaker systems, this results in even coverage throughout. Job done.



LINEA FOCUS LFI-450

White, RAL-9010

LINEA FOCUS LFI-450

White, RAL-9010



How do you spell “reverberation” in Swiss again?

MARKTHALLE BASEL, SWITZERLAND

The Markthalle in Basel is one of the city's landmarks. Originally built in 1929, it was re-opened in 2012 following a two and a half year programme of renovation. During this renovation, the building was equipped with a new sound system. Given its acoustic conditions, including a 14-second reverb time and echoes due largely to the building's 60m diameter cupola, appropriate loudspeaker options proved limited.

A convincing demonstration resulted in the choice of two 4.5 metre Linea Focus LFI-450 systems in a concrete grey colour (RAL 7023), which not only met the acoustic requirements, but also the visual ones in this historically protected building. The loudspeakers also function as electro-acoustic emergency warning systems.

LINEA FOCUS LFI-450
Special colour

LINEA FOCUS LFI-450
Special colour

One of the world's most beautiful cathedrals.
And one of the world's greatest acoustic challenges.

MAINZ CATHEDRAL, GERMANY

LINEA FOCUS LFI-350

LINEA FOCUS LFI-450

LINEA FOCUS LFI-450

LINEA FOCUS LFI-350

Mainz Cathedral is one of the world's most architecturally significant, historic houses of worship. What's more, it has an impressive series of statistics to match. Construction of the cathedral began in 975, making it over 1000 years old. The building itself covers a vast 4600 square metre area and can accommodate up to 4000 worshippers. Ceiling heights of between 28 and 54 metres can be found in the interior of the 116 metre long cathedral, which also has a lengthy 12-second reverberation time. Acoustically, the building is in a league of its own, with a reputation for being "extremely challenging". The same can also be said of the demands involved in planning and installing the cathedral's new sound system.



LINEA FOCUS LFI-220
special colour, RAL-9010

New Apostolic church Bad Oeyenhausen, Germany

System integration: Pfeffer GmbH, Soest



LINEA FOCUS LFI-220 **LINEA FOCUS LFI-220**
special colour, RAL-9010 special colour, RAL-9010

Castel church of the University of Bonn, Germany

Every church is both individual and unique.

Imagine being inside a typical church with its large interior and lofty ceiling. Church floors, ceilings and walls are usually made from stone or marble - highly reflective materials that frequently result in difficult acoustic conditions and long reverberation times. While these conditions can add to the appeal of some typical "church sounds", such as an organ or choir, they can also cause major problems with the reproduction of speech and contemporary electronic church music. Speech intelligibility frequently suffers, as the spoken word sounds strained or is hard to understand. Conventional church loudspeakers i.e. column speakers, can sound very pale and thin and are not really suitable for the reproduction of modern sacred music.

Knowing these problems, Fohhn® engineers have developed the Linea Focus and Focus Modular series of loudspeaker systems. The sound coming from these loudspeakers can be directly and precisely steered towards the listener, so that it does not stray uncontrollably onto the ceiling, floor or back wall. Unwanted reflections are considerably reduced, so that the sound heard by the listener appears less "washy" or "reverberant". The overall effect is more pleasant, with excellent levels of speech intelligibility, while any potentially disturbing influences from the room acoustic are minimized.

However, every church is both individual and unique. Requirements vary according to the contextual orientation and faith, so Fohhn® offers extensive support to parishes, planners and installation companies during the planning and measurement of each sound system. Certified Fohhn® Partners can take over the installation, support and service at a venue, with additional advice and support available from Fohhn® to ensure that the church or parish is always fully satisfied.



2 x LINEA FOCUS LFI-220
special colour, RAL-9010

52 Church "St. Maria de Victoria", Ingolstadt, Germany



2 x LINEA FOCUS LFI-350
special colour, RAL-9010

Church of Reformation Scherpenzeel, Netherlands

Sound meets vision

Installing an active outdoor sound reinforcement system in a country where it rains for up to 200 days a year may seem an impossible challenge. But it can be done, provided that the appropriate precautions are taken. The requirements of this particular installation were quite complex: On one side of the display wall, sound coverage of up to 70 metres was required. On the other side, people standing over 40 metres away needed to be able to hear every word clearly, without being disturbed by reflections or echoes from the neighbouring buildings. Somehow, the loudspeaker system also had to be integrated into the display wall to withstand the inclement English weather.

at Media City, Manchester.

Such requirements simply can't be fulfilled using conventional loudspeaker systems, so the only solution for this project was the Linea Focus LF-220. By adapting the beam dispersion characteristics, a narrow beam has been used to cover the enormous distance on one side, while minimizing any reflection from the buildings on the other. The loudspeakers themselves have been seamlessly integrated into the display wall's metal housing and an additional weather resistant fabric has been mounted to the front of the speakers to protect them from the weather.

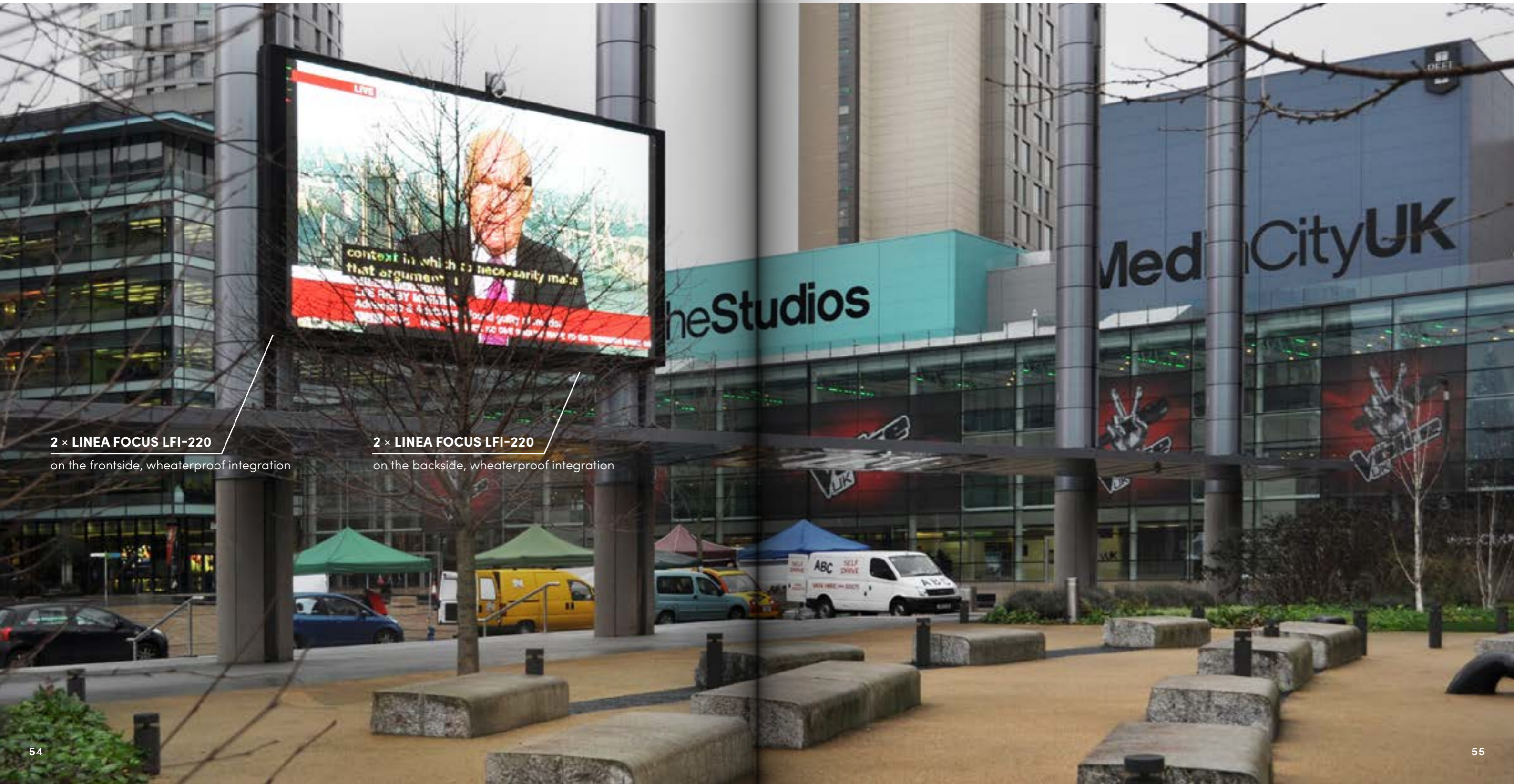

2 x LINEA FOCUS LFI-220

on the frontside, wheateproof integration

2 x LINEA FOCUS LFI-220

on the backside, wheateproof integration



Making sure you don't miss the train ...

MESSE/DEUTZ STATION,
COLOGNE, GERMANY



Cologne Deutz station acts as the main hub for both national and international passenger transportation to the Messe Cologne exhibition centre. Dating from 1845, the three-winged complex with its circular entrance hall was built in the style of a baroque rotunda. Its domed roof is considered an architectural masterpiece. However, what constitutes a masterpiece on the one hand can also be regarded as an acoustic challenge on the other, due to the height of the domed roof and the building's numerous stone and concrete reflective surfaces. A project for which there was ultimately only one appropriate loudspeaker system, the 4.5 metre long Linea Focus LFI-450.



LINEA FOCUS LFI-220

White RAL-9016

LINEA FOCUS LFI-220

White RAL-9016

IHK conference room, Wuppertal, Germany

System integration: avi-sys Kommunikationstechnik GmbH, Wesseling

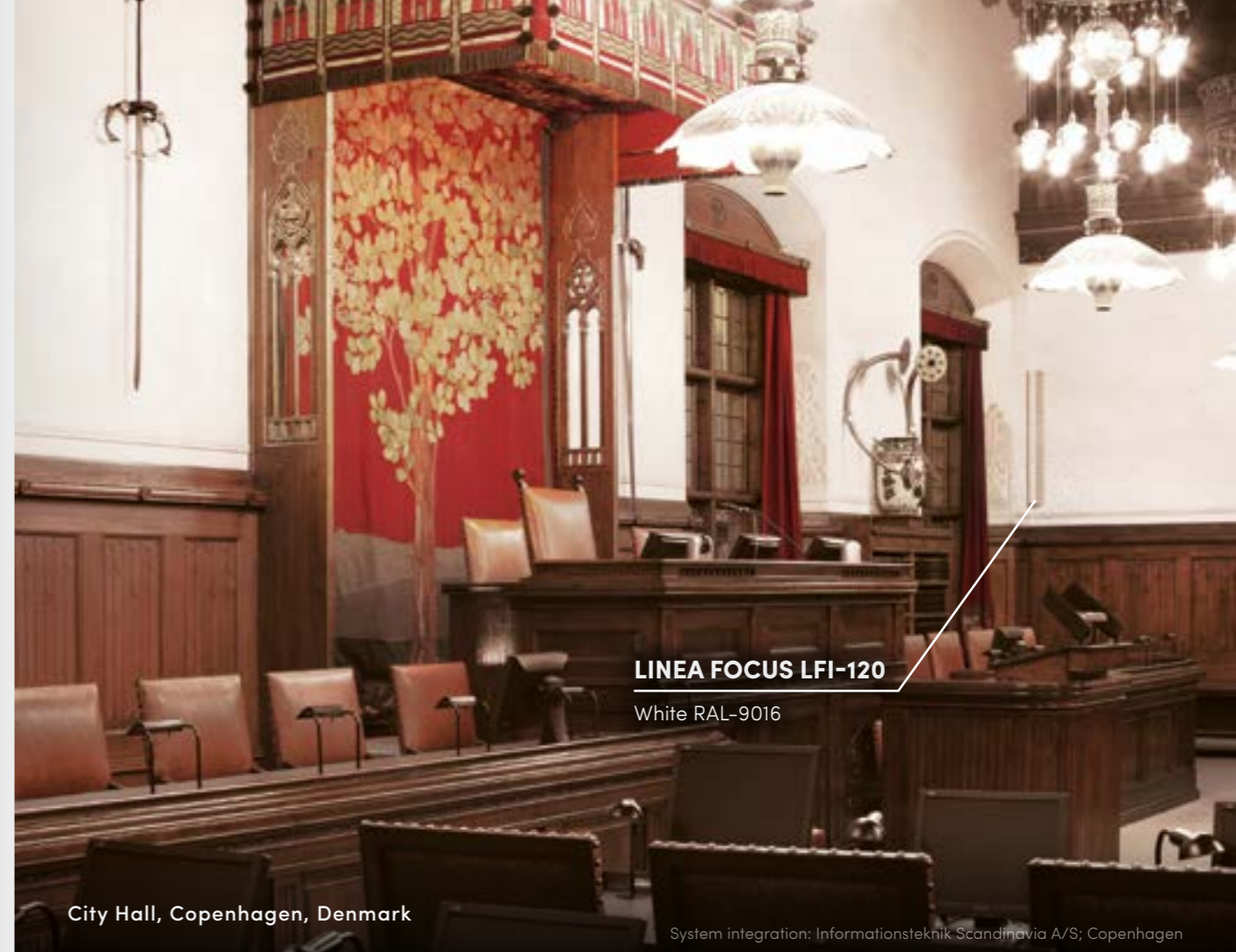

LINEA FOCUS LFI-120

White RAL-9016

City Hall, Copenhagen, Denmark

System integration: Informationsteknik Scandinavia A/S, Copenhagen

Clarity of word, Clarity of thought.

Whether in the "Welsaal" of the Federal Foreign Office, Berlin, or the City Hall in Copenhagen, important discussions can last a while. So it's important that any signs of fatigue aren't due to a poor sound system. After all, focussing on trying to hear what's being said is an unnecessary waste of energy.

The Linea Focus loudspeaker systems installed in these conference rooms offer effortless listening at comfortable volume levels, along with outstanding clarity. However, the benefits provided by such systems don't just apply to world-class conference facilities: A wide range of small and large conference rooms – from Iceland to China – have been equipped with Fohn® beam steering systems.



LINEA FOCUS LFI-450

"Welsaal", Federal Foreign Office, Berlin, Germany

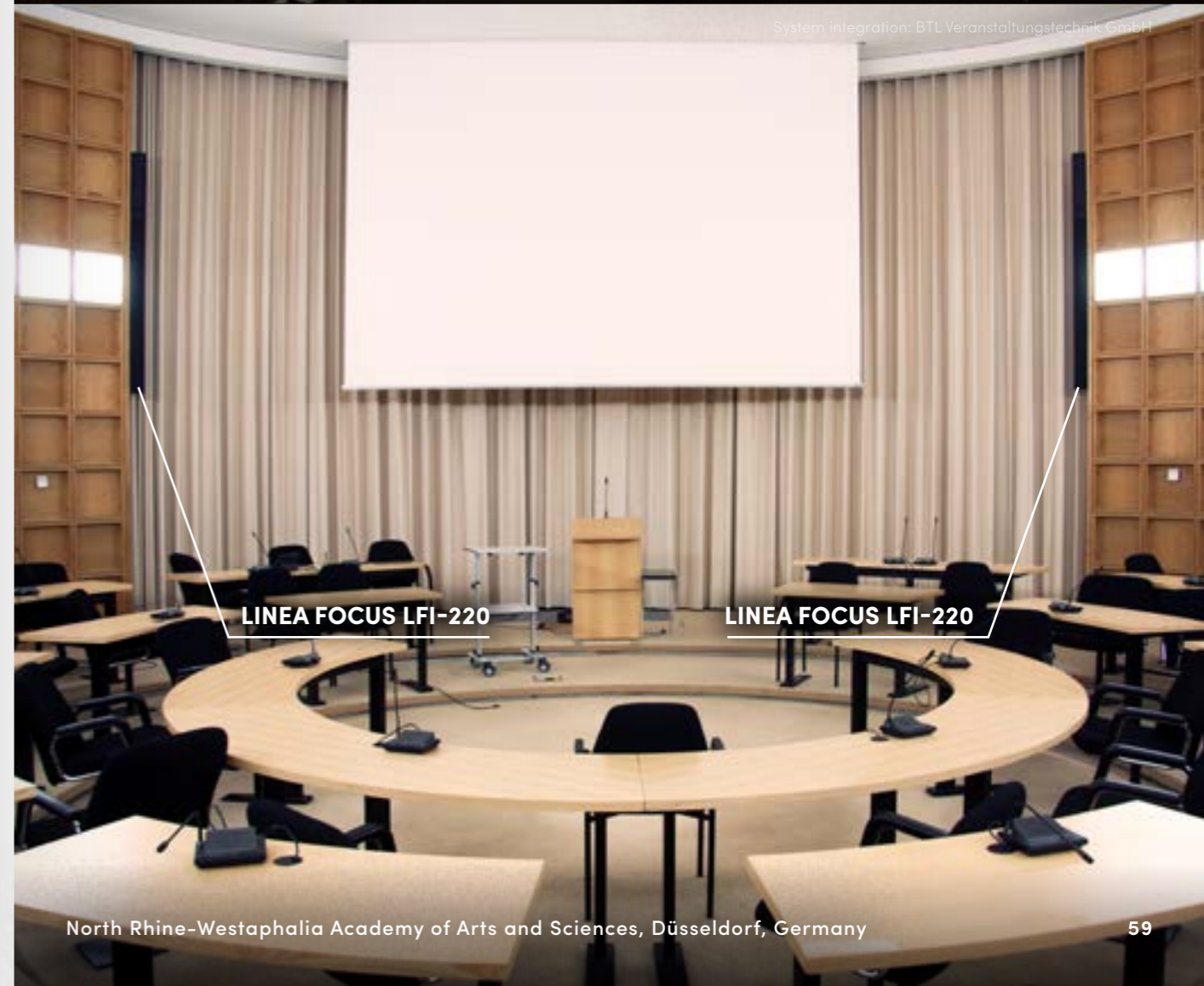

LINEA FOCUS LFI-220

LINEA FOCUS LFI-220

North Rhine-Westphalia Academy of Arts and Sciences, Düsseldorf, Germany



Mountains in Focus.

**“HAUS DER BERGE”, MUSEUM OF NATURAL SCIENCE,
BERCHTESGADEN, GERMANY**

In the “Haus der Berge”, the wonders of nature are presented in a multimedia exhibition: Its centrepiece, the “Vertikale Wildnis” panoramic landscape, gives an overview of the entire spectrum of life in the UNESCO recognised biosphere region. A highlight is the actual re-creation of a mountain from which visitors can view the impressive natural surroundings on a 15-metre wide projection complete with sound effects. The various graphic, photographic and video elements are combined with an elaborate light and sound show. Fohhn® Linea Focus LFI-120 systems, invisibly integrated into the backdrop, have been used to provide the high-quality soundscape.



A classic venue for worship and culture.

CITY CHURCH ALTER MARKT, MÖNCHENGLADBACH, GERMANY

LINEA FOCUS LFI-350

Mönchengladbach's City Church Alter Markt reopened in Autumn 2013 after a renovation programme lasting several years. While still functioning as a religious venue, the building is also used for cultural events, concerts, panel discussions, readings and other events alongside the regular services. During its renovation, the church's sound system was completely replaced.

The City Church is now equipped with two Fohhn® Linea Focus LFI-350 systems mounted on a special steel construction. During events, this construction also enables aisle seating to be separated from the altar area by use of a curtain. In the reverberant acoustics, the 3.5 metre long Fohhn® beam steering systems guarantee clear transmission of the spoken word as well as powerful sound reproduction of orchestral and band concerts.

STATEMENT OF ANDREAS JÜTTEN, PROJECT PLANNER

"Our greatest challenge was the choice of loudspeaker systems. Many factors needed to be taken into account: building preservation, the aesthetics of the re-design, performance capability and of course budget all had considerable influence on the outcome. Loudspeakers from various manufacturers were tested, however with regard to speech intelligibility and musicality, none were as convincing as Fohhn's Linea Focus systems. Accessories for mounting and steering the system via network also needed to be considered, as well as the timeless, unobtrusive appearance of the speakers themselves. Even in these complex church surroundings with the unfavourable acoustic conditions, two 3.5 metre columns have proved more than adequate. The system can also be extended as required by adding two XS-30 active subwoofers.

For further enhancement, directional coverage was also recommended. The previous sound system was a classic ELA installation with 20 loudspeakers distributing sound throughout the room in an undefined manner. Now, the sound comes from the actual viewing direction of the audience. Speech reproduction is clear and effective, without sounding too harsh. Music reproduction benefits from both the location and the ability for complex sound structures to be reproduced pure and differentiated. Positive feedback has been received from both concert audiences and worshippers. The loudspeaker coverage is extremely even due to the beam settings. From its outset, this project has been professionally supported both by the manufacturer, Fohhn, and the system integrator Firma Teqsas from Hürth. Intensive cooperation and advice from both partners has led to successful results in every respect. The two Fohhn line arrays have more than surpassed our expectations of a modern sound system."

LINEA FOCUS LFI-350



10 × LINEA FOCUS LFI-120

White, RAL-9016

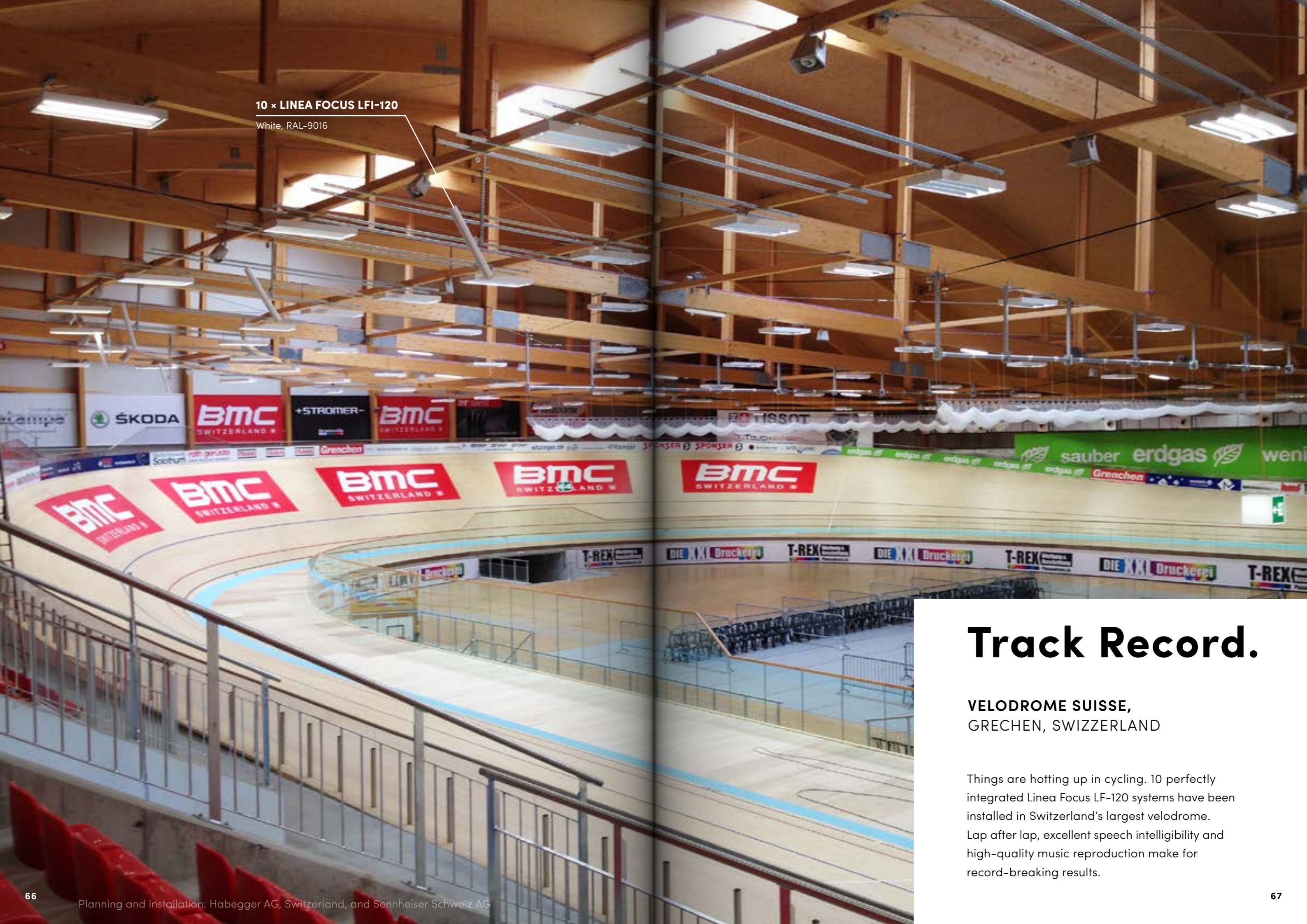

Track Record.

**VELODROME SUISSE,
GRECHEN, SWITZERLAND**

Things are hotting up in cycling. 10 perfectly integrated Linea Focus LF-120 systems have been installed in Switzerland's largest velodrome. Lap after lap, excellent speech intelligibility and high-quality music reproduction make for record-breaking results.

Precise sound is in demand worldwide.

FOCUS MODULAR UND LINEA FOCUS AROUND THE WORLD.



Austrian Academy of Sciences, Vienna

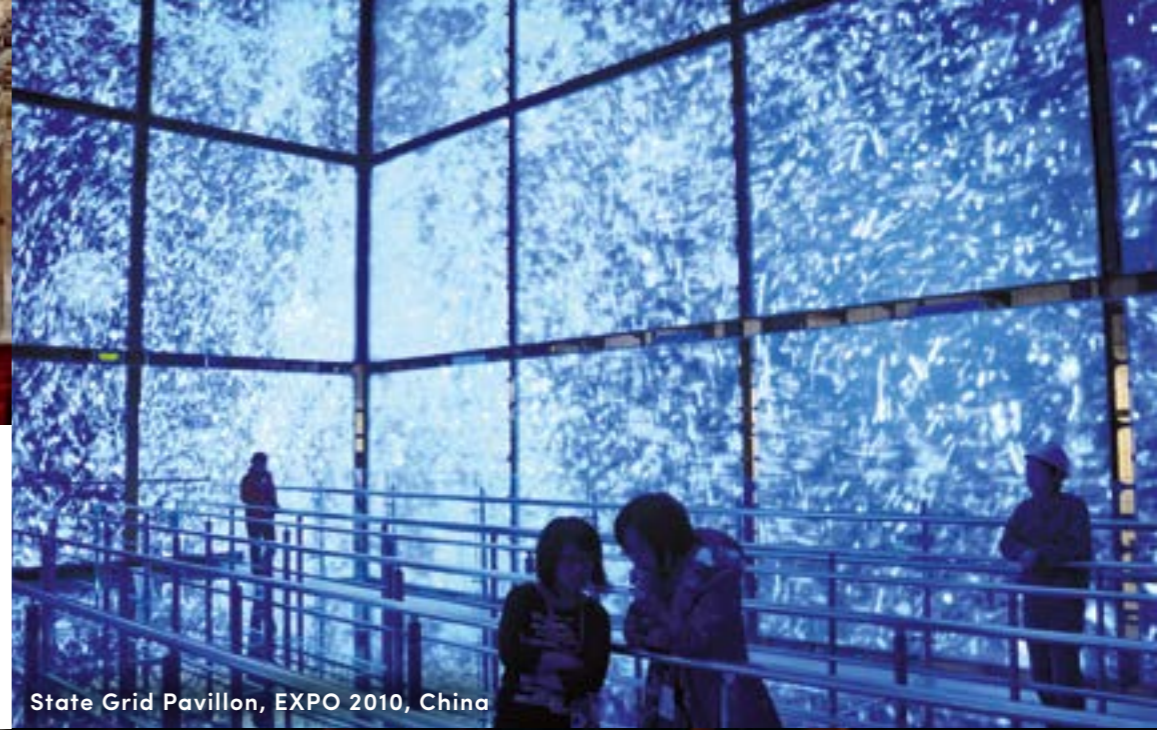

State Grid Pavillon, EXPO 2010, China



Mosteiro Monterol, Braga, Portugal



Danish Parliament, Denmark



Jaber Al Ali Mosque, Kuwait

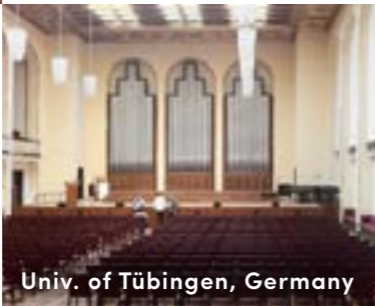

Univ. of Tübingen, Germany



Open-Air worship of the Pope, Porto, Portugal



Audi Urban Future Award, Venice, Italy



68 Keflavikurkirkja, Keflavik, Iceland



Zhejiang Provincial Party School, Hangzhou, China



Conference room, Philips, Eindhoven, NL

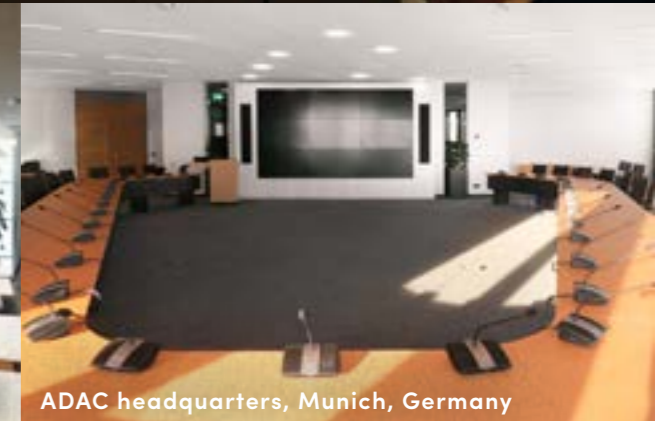

ADAC headquarters, Munich, Germany

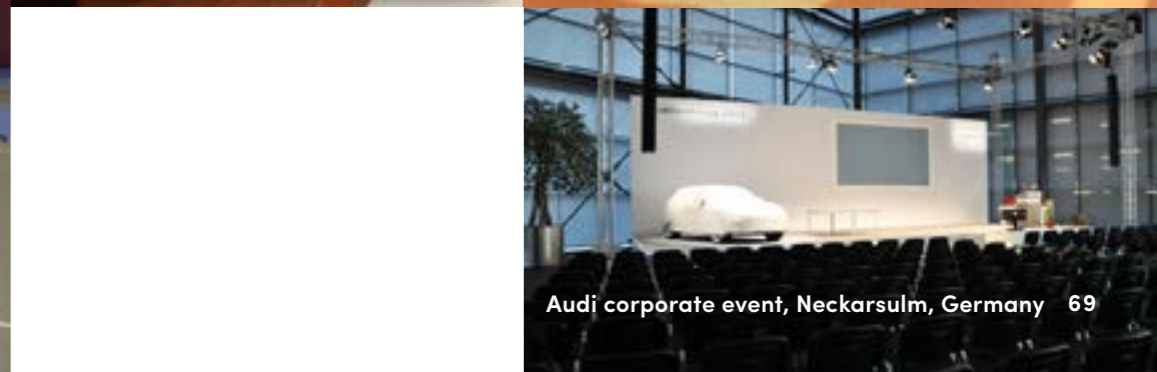

Audi corporate event, Neckarsulm, Germany 69

How do you actually develop Sound?

THE TECHNOLOGY BEHIND OUR BEAM STEERING SYSTEMS.

New paths to tread, innovative solutions to develop and the highest technical levels to aim for – these are our goals. An identical approach is applied with electronics and software through to acoustics and mechanics. Creative concepts for new loudspeakers are quickly translated into theory based on extensive calculations. Numerous computer simulations and prototyping phases follow in which each parameter is recorded and optimised: frequency response, dispersion characteristics, dynamics, distortion and large signal response. The next stage involves specifically optimising the amplifier electronics, digital signal processors (DSP) and remote control/networking technology for the loudspeaker. The result – a new and innovative product fully primed for high performance and true listening pleasure.

The Fohhn® SoundLab.

INTENSIVE RESEARCH AND SUSTAINED DEVELOPMENT –
FOHNN'S ROUTE TO PERFECT SOUND QUALITY.

With an area of 24 m x 14 m x 6.5 m, the Fohhn® SoundLab is one of Germany's largest and best equipped audio measurement facilities. A major investment in absorption and diffusion materials has turned the former industrial premises into an acoustically optimised listening environment. With 4-second reverberation time, the Sound Lab offers excellent test conditions. Developers can measure every single parameter of a loudspeaker system with the utmost precision and immediately analyse the data collected during test sessions. Only under such specialist conditions can a loudspeaker's performance be optimised to the highest level. A combination of room size and highly developed FFT measuring systems make it possible to obtain reflection free measurements down to 100 Hz – something that is usually difficult to achieve in the audio industry.



THE FOHNN® 2-AXIS MEASUREMENT ROBOT

One of the SoundLab's many technical highlights is the impressive measuring robot. The robot has been specially developed by Fohhn® for measuring extremely large loudspeaker systems. It can pan through both speaker axes at 360°, with a positioning accuracy of 0.3°. With the robot's help, each loudspeaker's directional characteristics can be assessed and optimised during every development stage – from speaker chassis through to finished prototype. The polar pattern data obtained by running Fohhn® loudspeakers through room simulation programs can also be analysed and optimised. This is achieved by making several hundred individual measurements, with the robot positioning itself at a different angle each time. A series of measurements for a single system can take up to 12 hours to complete.

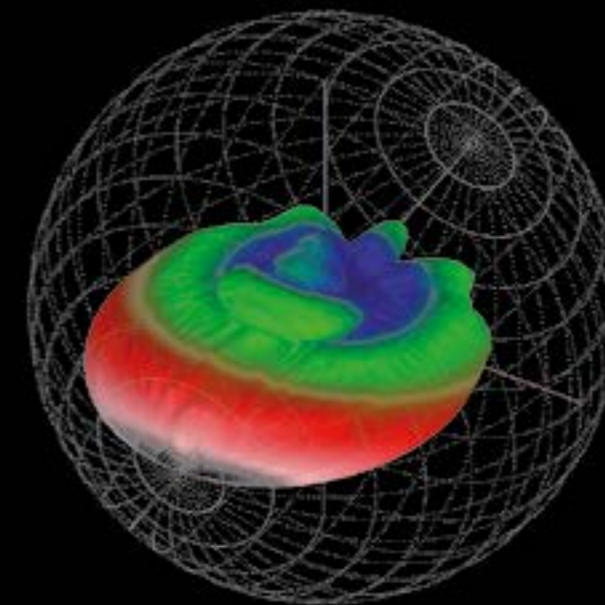

Why go to anyone when there's an **expert** available?

Fohhn® loudspeaker systems have been manufactured in Germany for over 20 years and are renowned for their outstanding workmanship and sound quality. As the company has developed, its goal has been to provide the customer with solutions that involve state-of-the-art technology and complex functionality, but are easy to use. In addition to manufacturing high quality products, we also want to make sure that end users are able to achieve the best possible results. That's why we have created the Fohhn® Partner Programme in which specialist dealers are certified as either a "Fohhn® Partner" or "Fohhn® Sound Expert". Fohhn® Partners and Sound Experts are trained audio providers who have been approved to advise on Fohhn® products and their applications, including areas such as room acoustics, audio system planning, room simulation, installation and measurement.

Fohhn's in-house planning and project engineers are always on hand to support a Fohhn® Partner and Sound Expert throughout an entire project. With their extensive technical knowledge and practical experience, they are happy to advise every step of the way and can even assist during the final stages of testing at a venue. The aim is always to help the customer achieve good results. For challenging live sound applications involving Linea Focus or Focus Modular systems, experienced Fohhn® sound engineers are also available to offer support at venues. The Fohhn® SoundLab plays host to a series of regular training and professional development events for Fohhn® staff, Fohhn® Partners, Sound Experts and other professionals. We also offer regular trainings, workshops and seminars in Nürtingen. Finally, it's important to make sure that you speak to an appropriate project partner. They can all be identified by their logos:

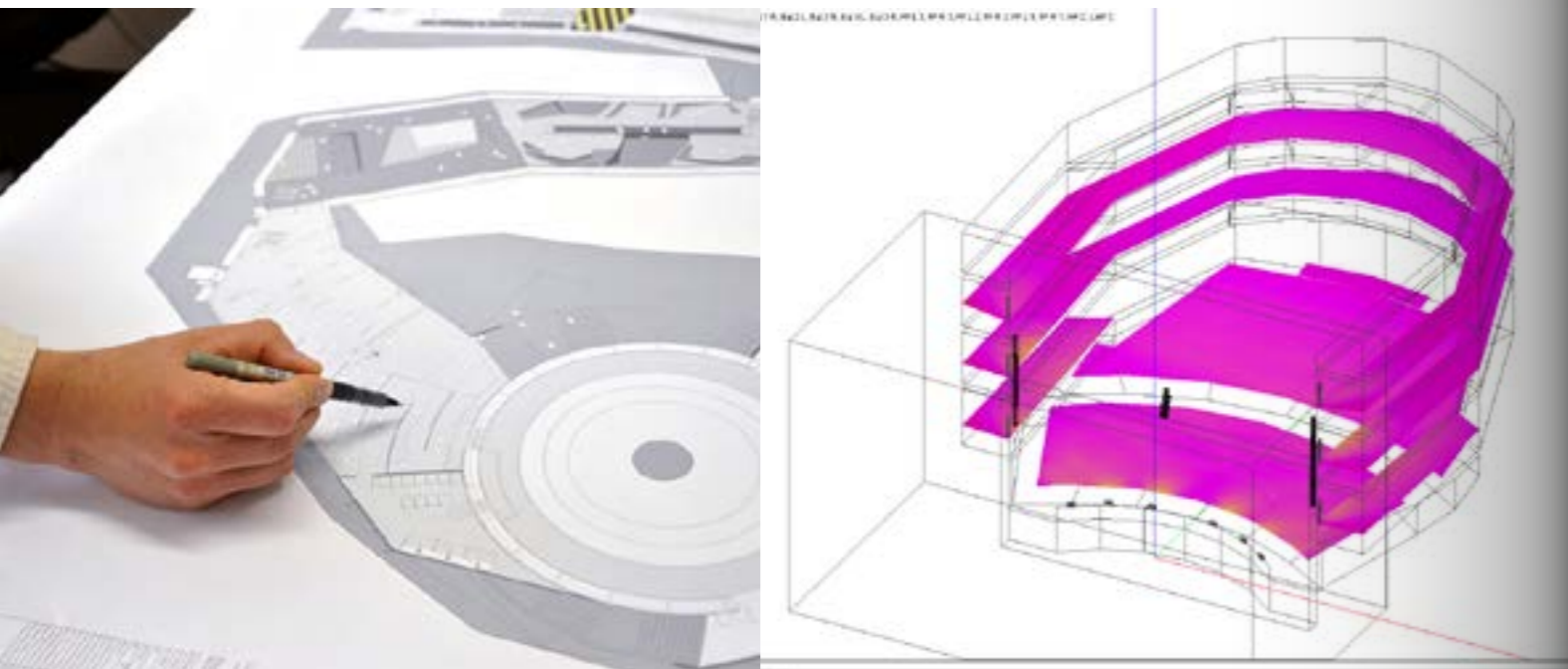

Project planning and expertise

Room simulation



Calibration of speaker system with Fohhn® FAMSA measuring system



Training and education

Fohhn® Audio Soft.

ONE PIECE OF SOFTWARE LETS YOU CONTROL AN ENTIRE SOUND SYSTEM: **FOHNN® AUDIO SOFT.**

State-of-the-art technology and dedicated software have been closely developed in tandem by our engineers and finely tuned for perfect compatibility. No other software program is required; everything is included in a single intuitive application - Fohhn® Audio Soft. The advantages are obvious: No unnecessary waiting time while data is transferred between software programs, or computer processes are completed. Loudspeakers do not have to be muted at any time while settings are optimised. Both the software and loudspeaker systems are permanently online and in constant communication with one another. Every adjustment can be made in real time, guaranteeing problem-free live control of all connected Fohhn® systems.

Free download from www.fohnn.com

- Direct and intuitive remote control of Fohhn® systems in real time
- Clear graphical user interface gives speedy access to all connected digital audio devices, group functions, sound presets and Focus Simulation
- All settings can be saved as presets
- Up to 256 devices can be networked and remotely controlled



SIDE LOBE FREE TECHNOLOGY

Developed in house, this algorithm is specially designed to suppress naturally occurring but unwanted side lobes. This results in more direct coverage and greatly improved speech intelligibility, especially in reverberant acoustic conditions.

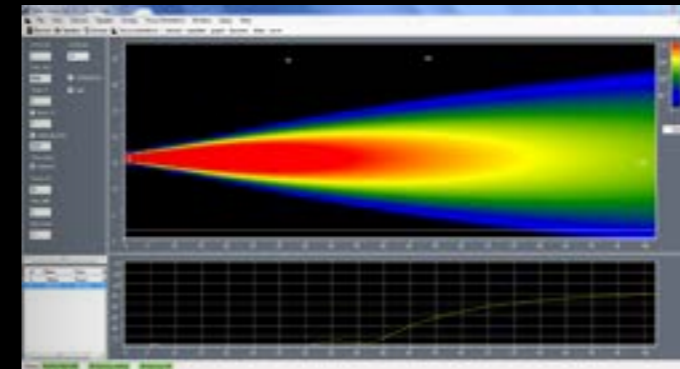

With Side Lobe Free Technology

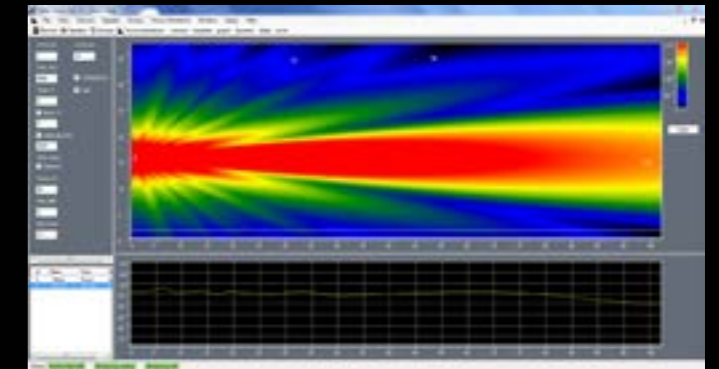

Without Side Lobe Free Technology

TWO BEAM TECHNOLOGY

Also developed in house, Fohhn® Two Beam Technology enables the generation of two separate beams per speaker. This applies to both the Focus Modular low-mid/full range and high frequency modules and for Linea Focus systems.

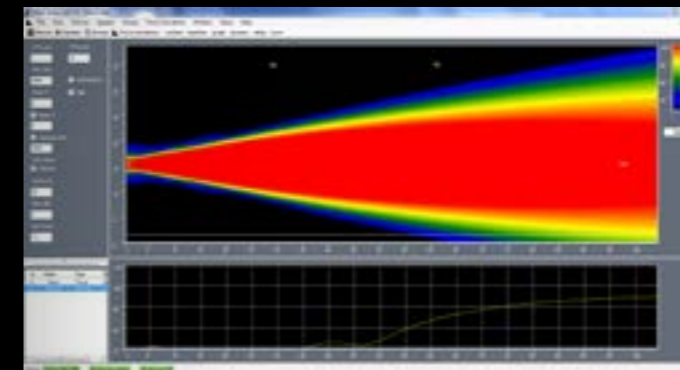

A single loudspeaker beam

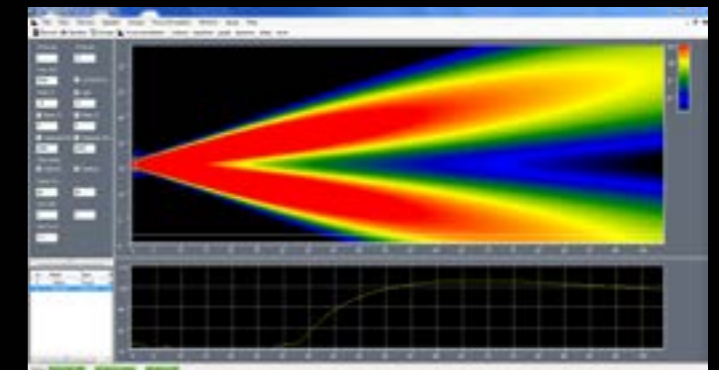

Two separate beams

Focus Sub Array

BEAM STEERING TECHNOLOGY FOR BASS ARRAYS.



- Remote control of the bass frequency range using Fohhn® Audio Soft
- Real-time beam steering in 0,1° increments
- Build horizontal, vertical or endfired bass arrays
- Even coverage of audience areas
- Reduction of troublesome room reflections
- Suppression of unwanted low frequency side lobes

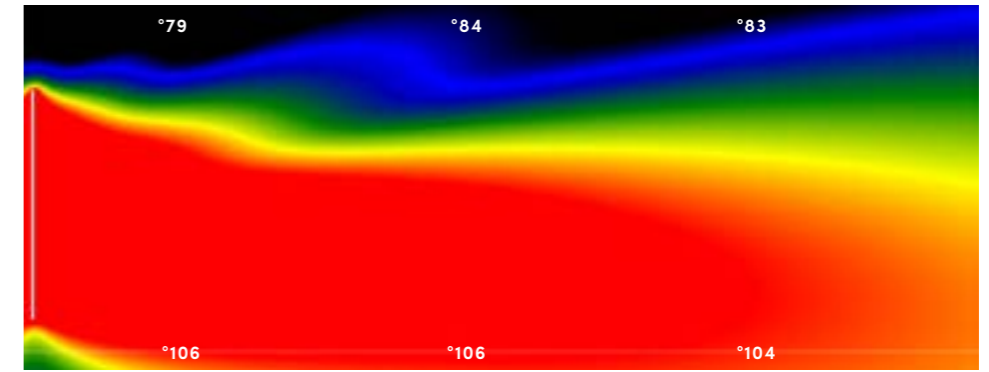

Vertical Bass Array

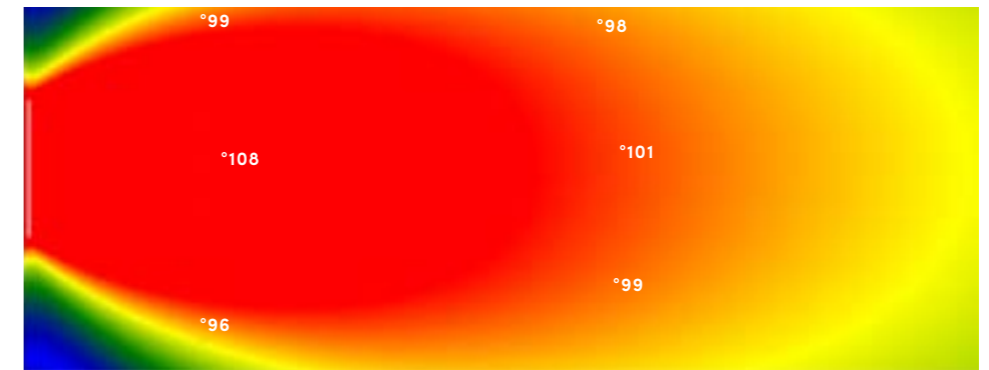

Horizontal Bass Array

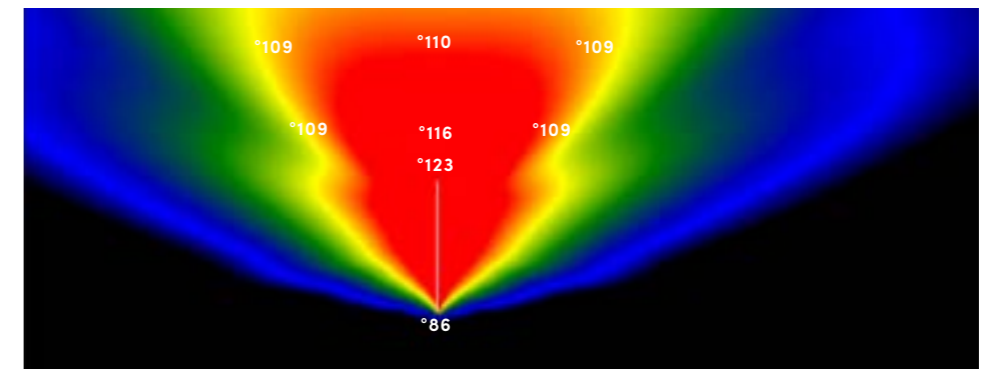

Endfired Bass Array

Combining multiple subwoofers to form bass arrays is a common practice in modern sound reinforcement. The technique enables subwoofer beam characteristics to be optimized and more precisely directed. However, the ability to control these beam characteristics in real time via software is completely new and unique. This is achieved using Fohhn® Audio Soft (from V. 3.4) in combination with Fohhn® DSP technology and Fohhn® subwoofers. For the user, there are tremendous advantages: Real-time control lets you see the directional characteristics of the beam via software simulation and hear the result at the same time. This ability to simultaneously see and hear what is going on enables effortless and accurate set-up and control of horizontal, vertical and endfired bass arrays.

Focus Modular

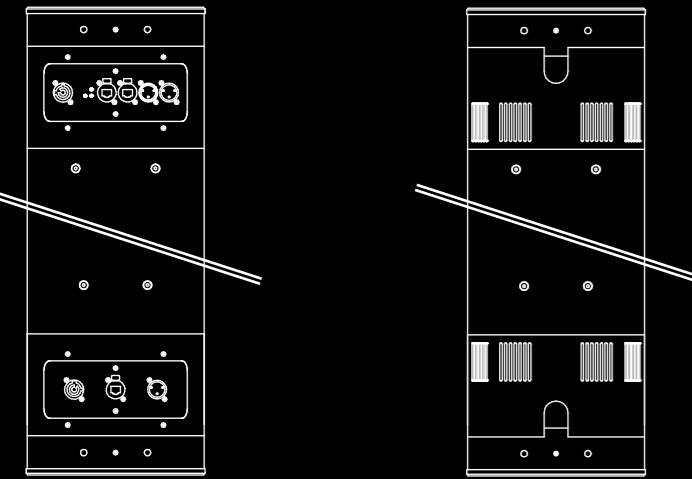

FM
Rear view 1:10

FMI
Rear view 1:10
(Internal connection sockets)

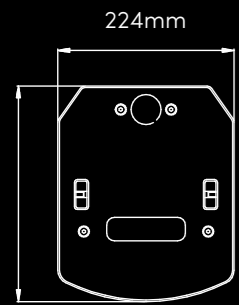

FM / FMI
View from above / Bottom view 1:10

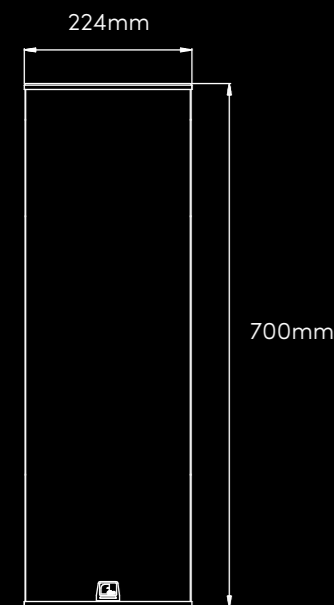

FM-100 / FMI-100
Front view 1:10

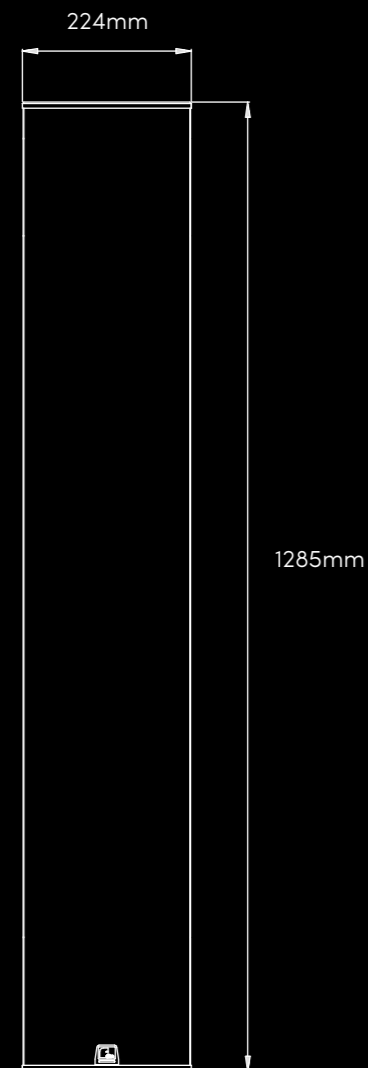

FM-110 / FMI-110
Front view 1:10

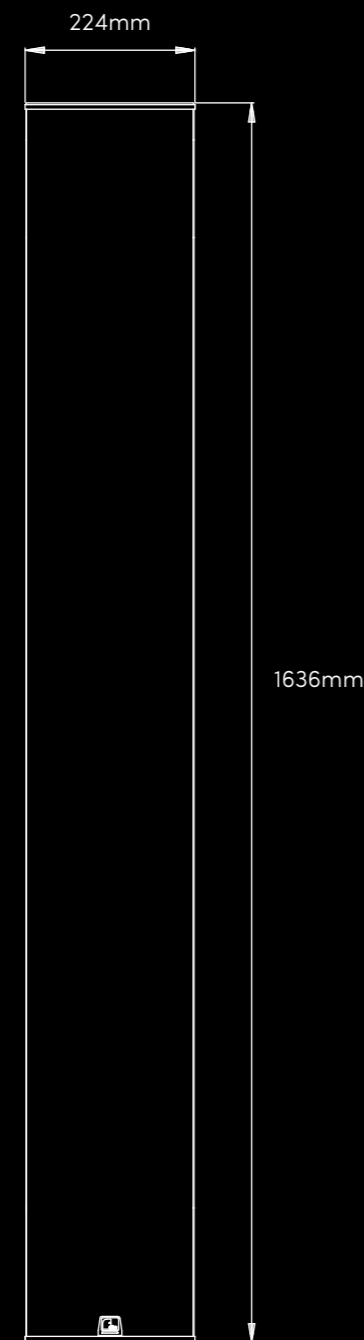

FM-400 / FMI-400
Front view 1:10

Linea Focus

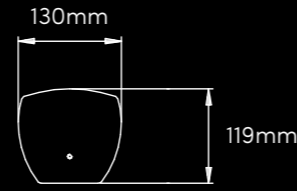

LFI
Bottom view 1:10
(Internal connection sockets)

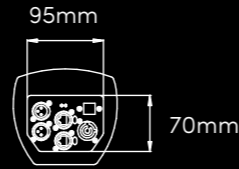

LF
Bottom view 1:10

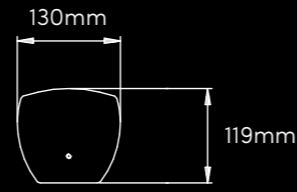

LF / LFI
View from above 1:10

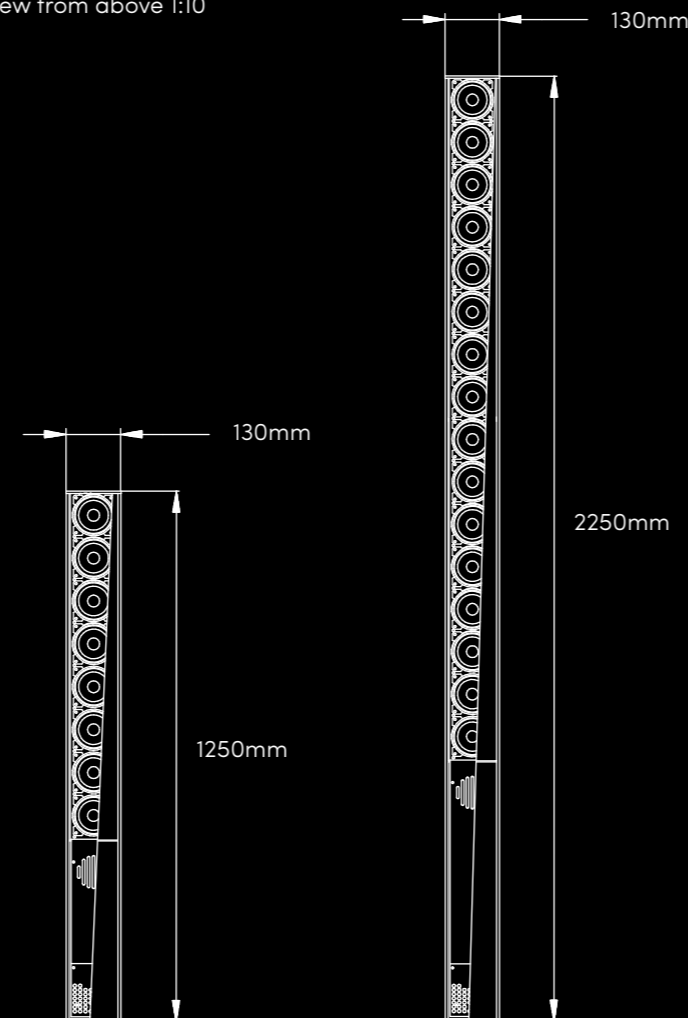

LF-120 / LFI-120
Front view 1:20

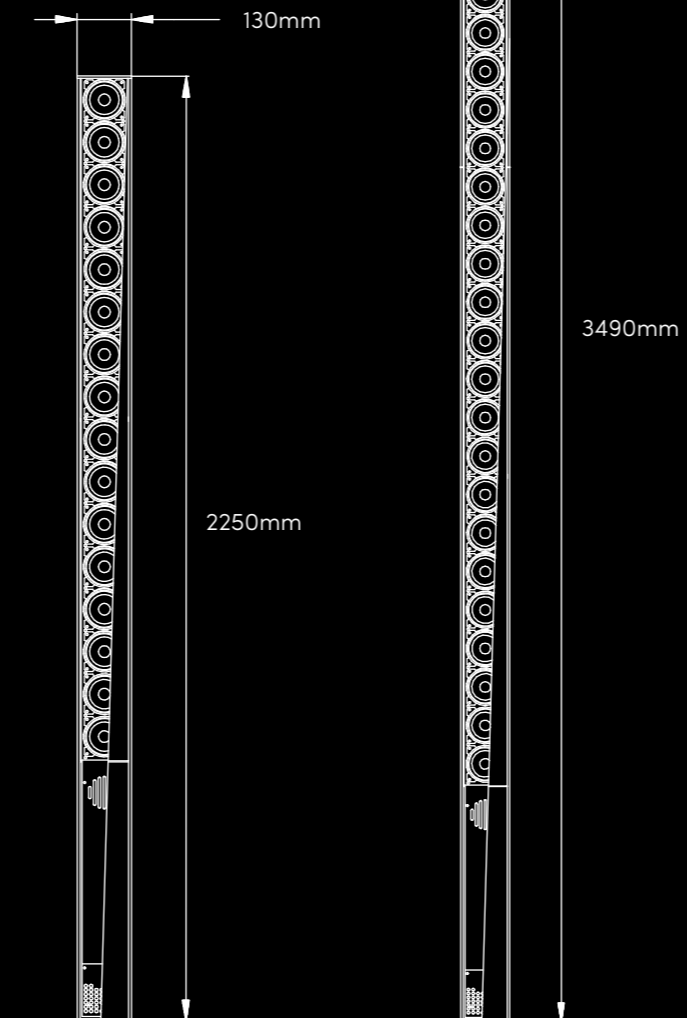

LF-220 / LFI-220
Front view 1:20

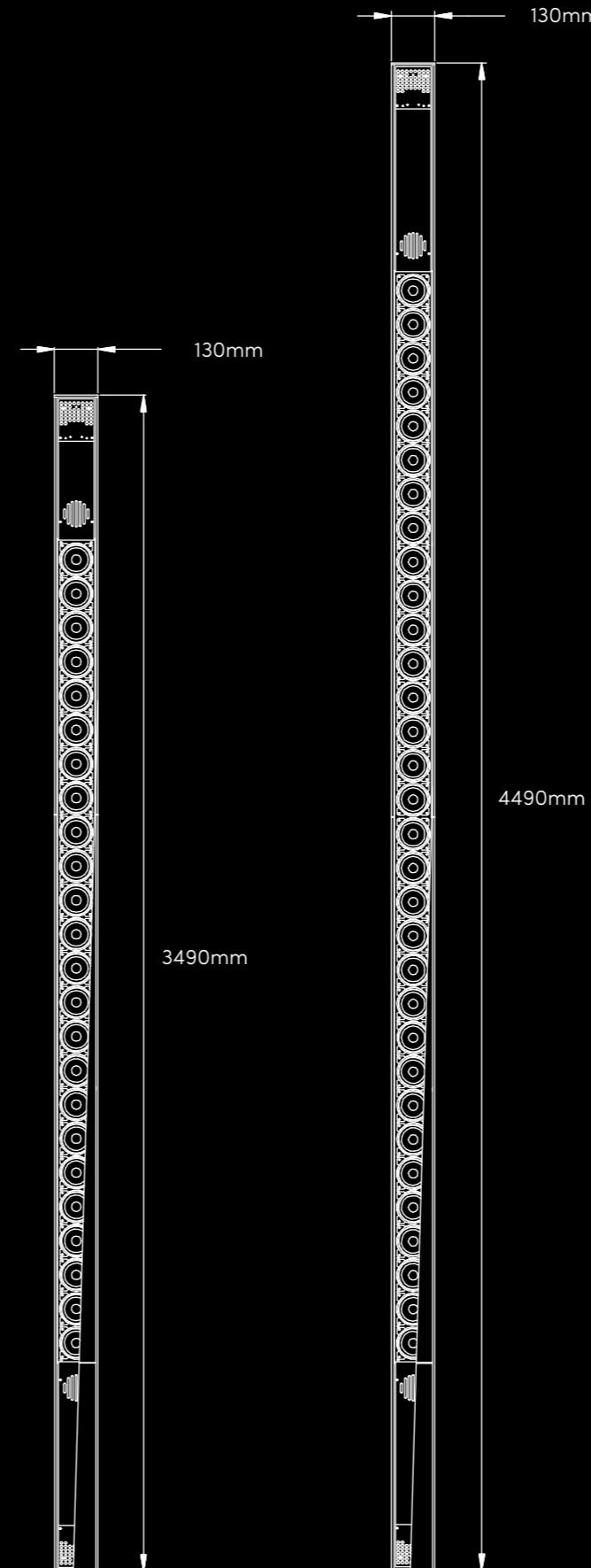

LFI-350
Front view 1:20

LFI-450
Front view 1:20

Free Stand Designer Stands

FOR LINEA FOCUS

Whether for fixed installation or mobile use, Fohhn's Free Stand designer loudspeaker stands ensure that Linea Focus systems integrate perfectly into any room architecture. Free Stands are either supported by a stand base or by a Fohhn® subwoofer.

Speaker cables can be concealed within the stand itself. The base has a series of connection sockets, which are covered. This allows the cabling to remain invisible.

- Perfect integration into any room architecture
- Elegant, unobtrusive design
- Sturdy, safe support for Linea Focus speakers
- Quick assembly
- Excellent workmanship "Made in Germany"
- Available in the same RAL colours as loudspeakers
- Special length available on demand

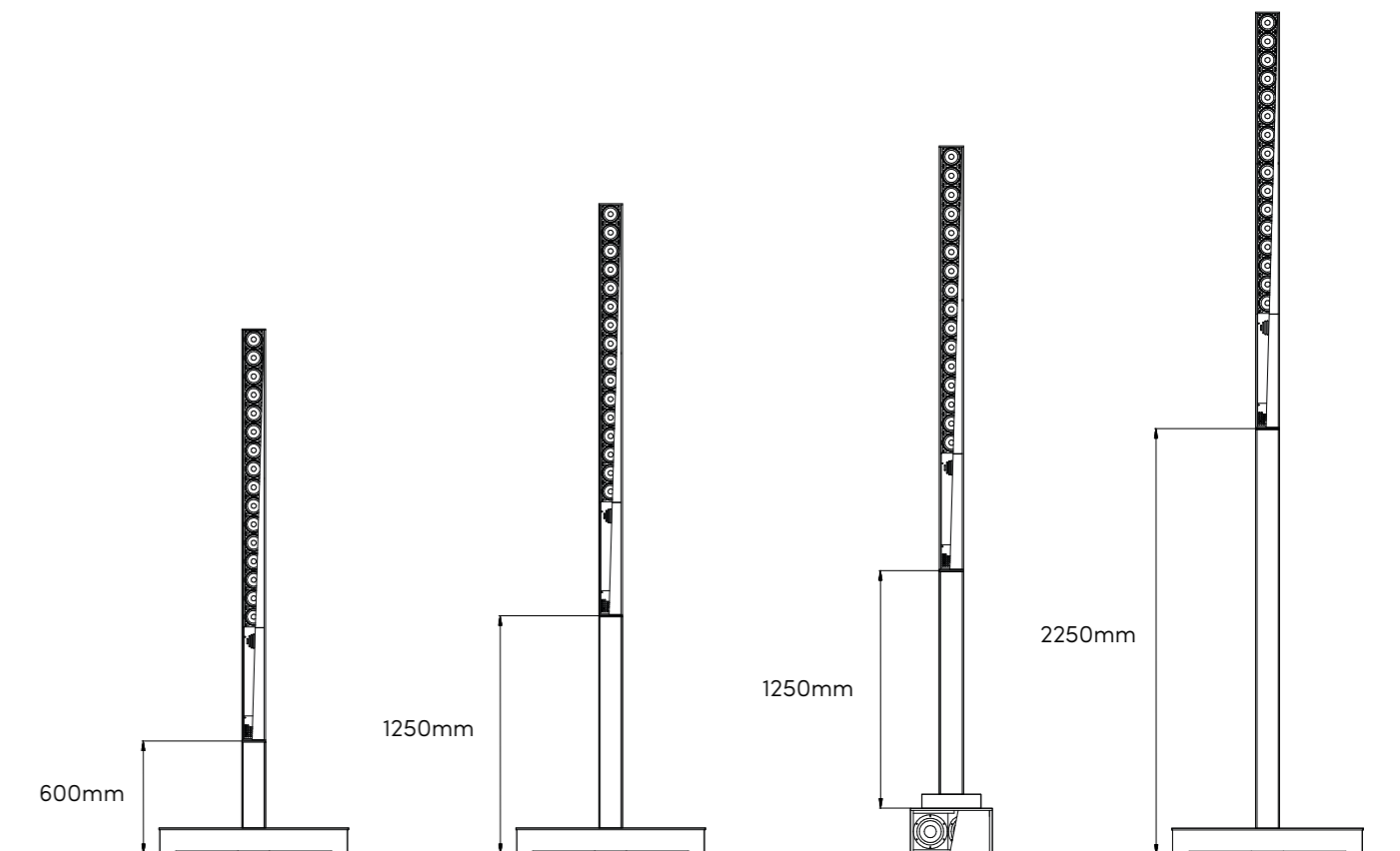

FREE STAND IX
Front view 1:40

FREE STAND X
Front view 1:40

FREE STAND X
on Fohhn® Subwoofer 1:40

FREE STAND XI
Front view 1:40

The functional principles.

This simplified diagram gives interested readers a basic overview of the functional principles. The input signal initially runs through the NF Signal In. This has a Priority Select that is primarily used to handle emergency evacuation information, guaranteeing maximum safety during an emergency. The input signal then passes through a digital signal processor (the User DSP), which offers an extensive range of real-time processing functions. These can be simply and intuitively accessed via Fohhn® Audio Soft control software. The »Speaker Setting & Protection« DSP contains all the various protection mechanisms such as a finely tuned multi-band limiter.

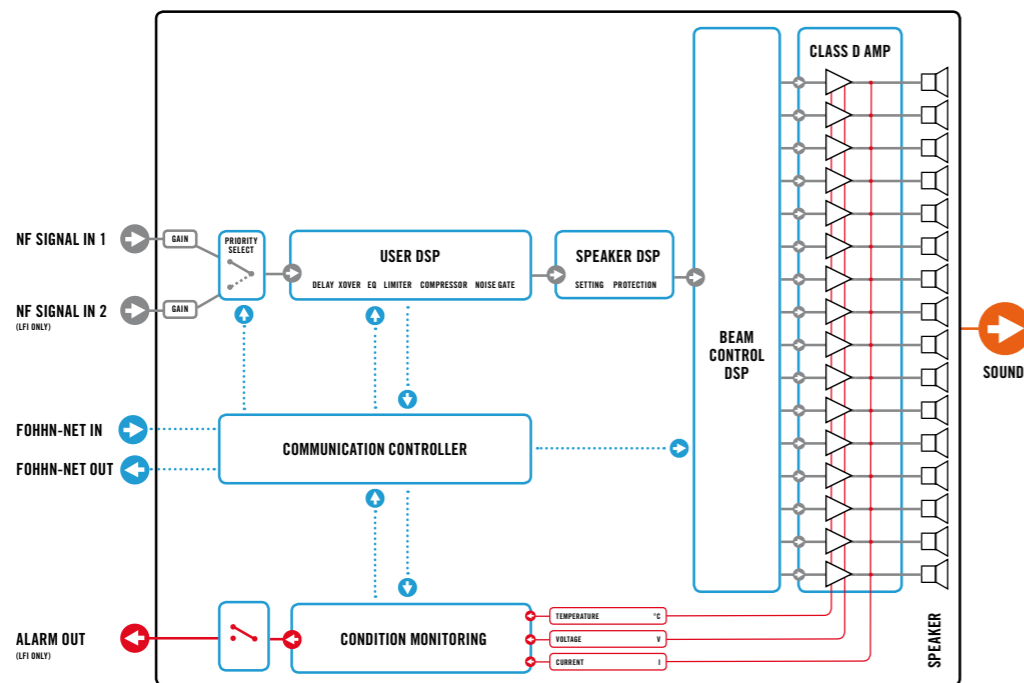

At the "heart" of all Focus systems is the »Beam Control DSP«. This contains the algorithms required for calculating the various beam characteristics. From here, all software beam steering settings made by the user are transmitted for realisation by the individual loudspeakers. Each speaker, with its specially calculated signal, is then driven by its own Class D amplifier. Constant monitoring of each individual output signal and of component conditions such as temperature, current and voltage enables the user to check on the actual operating status at all times. Any modified settings can be saved as presets.

Fohhn. The Experts in Beam Steering.

OUR LOVE TO DETAIL GOES FAR BEYOND THIS BROCHURE ...

On our website you can find detailed product descriptions, technical data, accessories and full data sheets for download, along with 360° product views, user guides, PDF brochures, CAD drawings, 2D and 3D DWG files, Fohhn® software, firmware updates, EASE and ULYSSES simulation data, references and much more. www.fohhn.com

FOHNN® LINEA FOCUS AND FOCUS MODULAR AWARDS:



Le Etoile du SIEL
Fohhn® Focus Modular



EMEA InAVation Award
2014 Technology Finalist
Fohhn® Focus Modular



Installation Europe
Editors' Award
Best of Prolight+Sound 2011
Fohhn® Focus Modular



MIPA Award
2009/2010
Fohhn® Linea Focus

FIND AND FOLLOW FOHNN® ACROSS THE SOCIAL WEB:



facebook.com/FohhnAudioAG



youtube.com/FohhnTV



twitter.com/FohhnAudioAG

WE ARE HAPPY TO HELP: **+49 7022 93323-0** OR **INFO@FOHNN.COM**



■ **GERMAN QUALITY**
■ **ENGINEERED AND MADE**
■ **BY FOHNN®**

Fohhn Audio AG
Hohes Gestade 3-7
72622 Nürtingen, GERMANY