



VTB Series

Voice/Tone™ Compression Drivers for Sirens



VTB-1

Features

- Patented Voice/Tone™ Loudspeaker for Custom Application in High Efficiency Industrial Communications, Intercom, Electronic Alarm, and Monitoring Systems
- Water/Moisture, Corrosion, Dust, Vibration, and Vermin-Resistant
- Metal Die-Cast Construction with Integral Exponential Horn
- High Efficiency Compression Driver for Optimum Audio Intelligibility
- Selection of four Models; 2 to 15 Watts, 4Ω or 8Ω, 70.7V or 25V Transformers
- UL-Recognized Speaker Component
- Operates Within a Temperature Range of -30° F to 150° F

Applications

VTB Series compression drivers combine exceptional performance, environment-resistance, and high-power sound distribution for reproducing voice and/or electronic tone signals with clarity and accuracy.

The driver-only design is intended for installation in custom housings used in high-efficiency industrial communication, intercom, electronic alarm and monitoring system applications including industrial, institutional, educational and health care centers, mass transit and mobile radio communications, government buildings and military installations, mines, jails, and detention centers, industrial processing, construction sites, drive-thru menu boards, and intrusion alarms.

Atlas Sound's VTB Series loudspeakers are UL-recognized for use as a component within a complete system.

General Description

Atlas Sound VTB Series Models are environment-resistant loudspeakers designed for intercom communication. VTB Models feature an integral exponential horn to provide reliable sound distribution and optimum intelligibility for the reproduction of voice and/or electric tone signals. Units have a frequency response of 600Hz – 5.5kHz (±5dB), and are offered in four models to meet application requirements.

Series Models VTB-1 and VTB-2 are 8Ω and 4Ω units, respectively. Models VTB-4 and VTB-6 are equipped with a built-in transformer. Termination is via 6" color coded leads. Units are of die-cast zinc construction with a water-sealed driver that will withstand moisture, corrosion, vibration, vermin, and vandalism. Models are available with a selection of multi-tap transformers and are designed to mount a variety of standard or custom housings and face plates to meet installation and application requirements. VTB Series units provide years of trouble-free service in stationary or mobile applications both indoors or outdoors.

Specifications

VTB-1

Transformer	N/A
Power Taps	15 Watts (8Ω)
Frequency Response	600Hz – 5.5kHz (±5dB)
Dispersion	> 190° (-6dB pt., 1 and 2kHz octave bands)
Sensitivity	96.9dB (1W / 1M) UL: 90dB * (1W, 10 feet)
Length	3 1/16" (93.7mm)
Width	3 1/16" (93.7mm)
Depth	3 3/16" (81mm)
Weight	2.23 Lbs. (1.12 kg)

VTB-2

Transformer	N/A
Power Taps	15 Watts (4Ω)
Frequency Response	600Hz – 5.5kHz (±5dB)
Dispersion	> 190° (-6dB pt., 1 and 2kHz octave bands)
Sensitivity	96.9dB (1W / 1M) UL: 90dB * (1W, 10 feet)
Length	3 1/16" (93.7mm)
Width	3 1/16" (93.7mm)
Depth	3 3/16" (81mm)
Weight	2.23 Lbs. (1.12 kg)

©2011 Atlas Sound L.P. All rights reserved. Atlas Sound and Strategy Series are trademarks of Atlas Sound L.P. All other trademarks are the property of their respective owners. AT5004143 RevA 7/12

©2011 Atlas Sound L.P. All rights reserved. Atlas Sound and Strategy Series are trademarks of Atlas Sound L.P. All other trademarks are the property of their respective owners. AT5004143 RevA 7/12

VTB-4

Transformer	25V
Power Taps	2, 4, 8, 15 Watts
Frequency Response	600Hz – 5.5kHz (±5dB)
Dispersion	> 190° (-6dB pt., 1 and 2kHz octave bands)
Sensitivity	96.9dB (1W / 1M) UL: 90dB * (1W, 10 feet)
Length	3 1/16" (93.7mm)
Width	3 1/16" (93.7mm)
Depth	3 3/16" (81mm)
Weight	2.23 Lbs. (1.12 kg)

VTB-6

Transformer	25V
Power TAPS	1, 2 Watts
Frequency Response	600Hz – 5.5kHz (±5dB)
Dispersion	> 190° (-6dB pt., 1 and 2kHz octave bands)
Sensitivity	96.9dB (1W / 1M) UL: 90dB * (1W, 10 feet)
Length	3 1/16" SQ (93.7mm)
Width	3 1/16" SQ (93.7mm)
Depth	3 3/16" (81mm)
Weight	2.23 Lbs. (1.12 kg)

* 3dB increment rating.

Architect and Engineer Specifications

UL-recognized environment-resistant loudspeaker shall be Atlas Sound Model _____ (VTB-1, VTB-2, VTB-4, VTB-6) or approved equal. Unit shall be comprised of a compression driver with integral exponential horn. Frequency response shall be 600Hz to 5.5kHz ±5dB with a sensitivity of 96.9dB (1W / 1M) and UL rating of 90dB. Model shall have a dispersion angle of 190° and shall be able to withstand temperatures ranging from 150° F (66° C) to -30° F (-35° C) Unit shall have a power rating of ____ (15 or 2 Watts) and shall ____ (include built-in 25 or 70.7V transformer) with primary watt taps of ____ (1, 2, or 2, 4, 8, and 15 Watts) or (be 4Ω or 8Ω). VTB Series Model shall be constructed of die-cast zinc and shall include a water-sealed driver that shall withstand moisture, corrosion, vibration, vermin, and vandalism.

VTB Polars (Normalized to Zero on Axis) (-6dB)

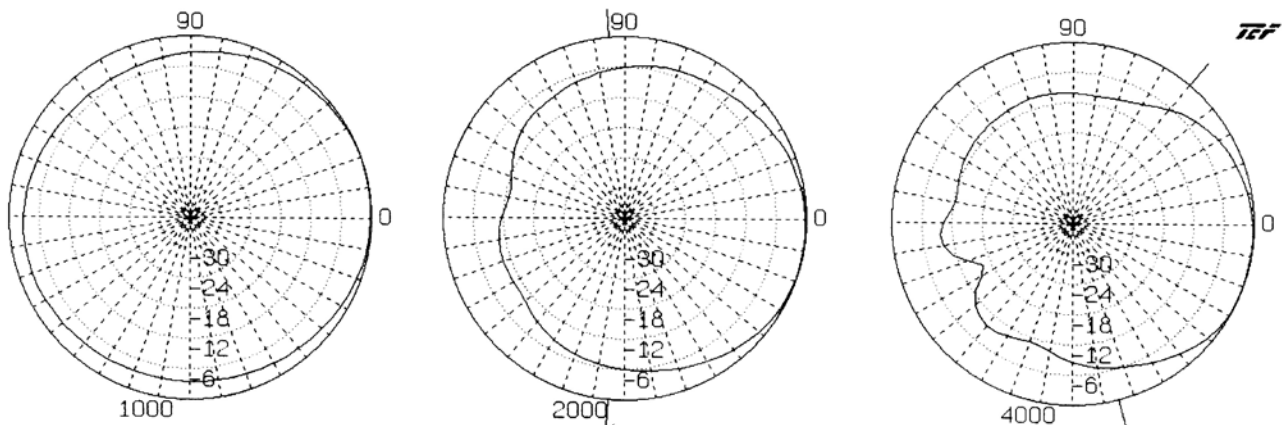

VTB Frequency Response

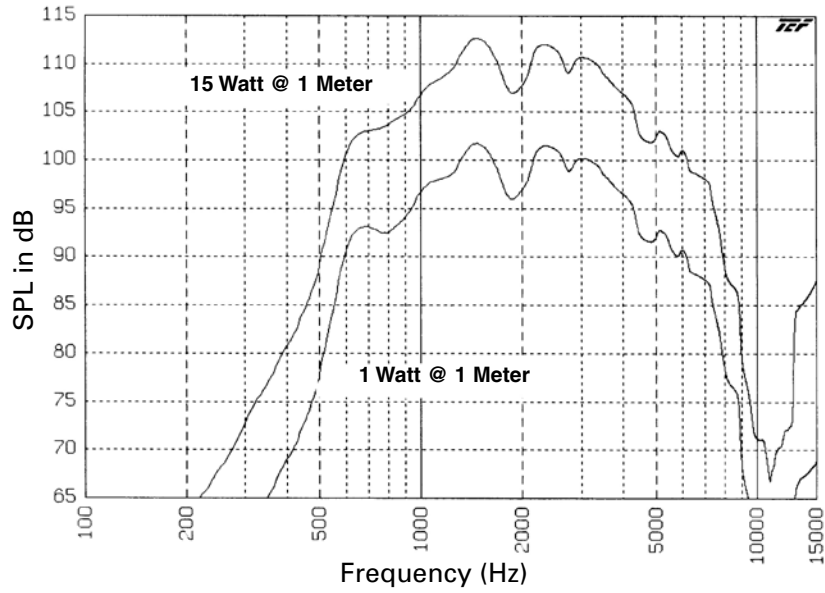

VTB Harmonic Distortion

